

COMMON FLUE GAS SYSTEM DESIGN MANUAL

C11 approved boilers.

CB 85 CH/HW

CB 105 CH/HW

CB 125 CH/HW

CB 155 CH/HW

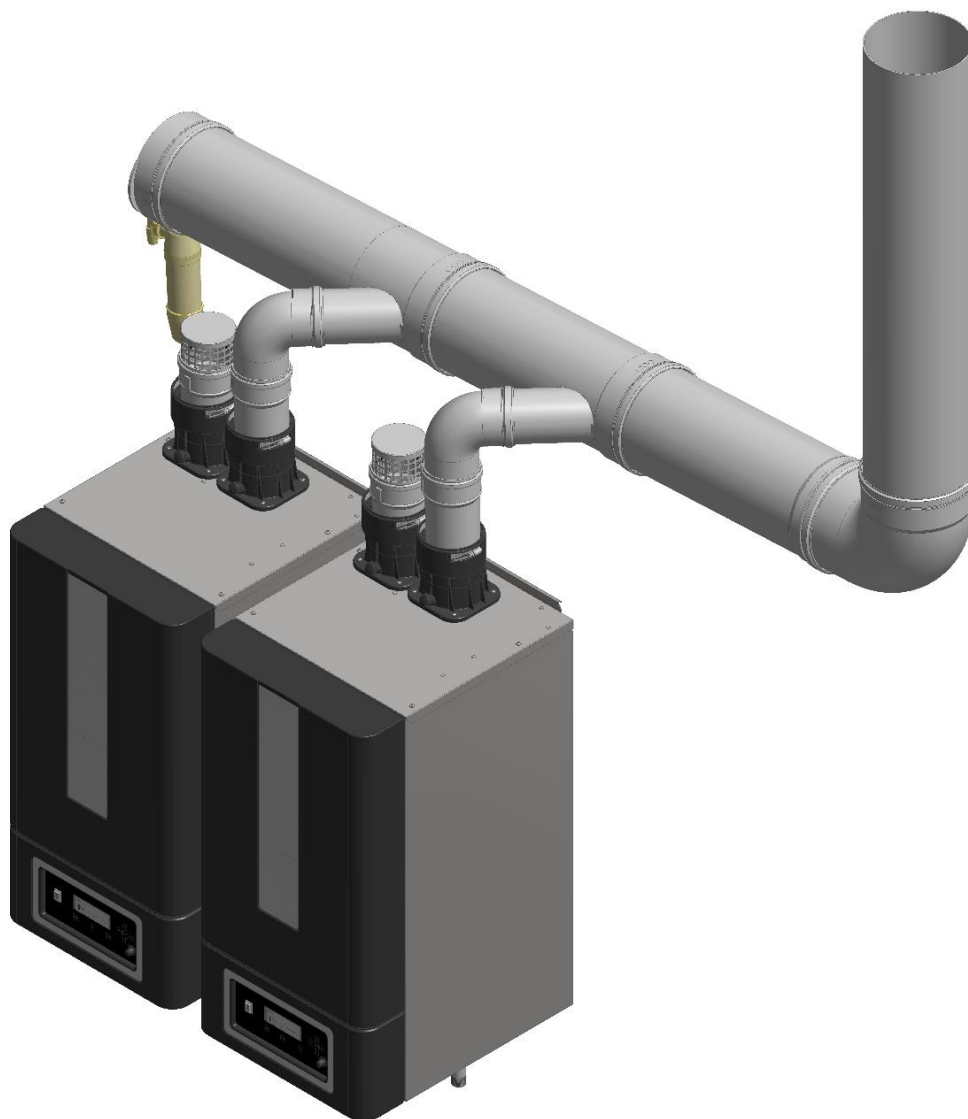

Table of Contents

1. WARNINGS AND DESIGN LIMITS	4
1.1 Flue gas discharge areas.....	5
1.2 Parameter settings.....	5
2. PIPE DIMENSIONS IN-LINE-SYSTEMS FLUE GAS ONLY	6
3. PIPE DIMENSIONS BACK-TO-BACK SYSTEMS FLUE ONLY	7
4. EQUIVALENT LENGHTS	8
4.1 Example Equivalent lengths.....	8
5. PIPE DIMENSIONS FLUE+AIR INTAKE IN-LINE	9
6. PIPE DIMENSIONS FLUE+AIR INTAKE BACK TO BACK	10
6.1 Example different length air intake and flue.....	11
7. SAFETY MEASURES COMMON FLUE SYSTEMS	12
7.1 Existing common venting guidelines.....	14
8. APPENDIX: DESIGN INSTRUCTION FLUE GAS SYSTEM	15
8.1 Twin pipe in-line CB 85-125.....	15
8.2 Concentric in-line CB 85-125.....	16
8.3 Twin pipe in-line CB 155.....	17
8.4 Twin pipe back to back on one collector CB 85-125.....	18
8.5 Concentric back to back on one collector CB 85-125.....	19
8.6 Twin pipe back to back on one collector CB 155.....	20
8.7 Twin pipe back to back on two collectors CB 85-125.....	21
8.8 Concentric back to back on two collectors CB 85-125.....	22
8.9 Twin pipe back to back on two collectors CB 155.....	23
9. APPENDIX: FLUE GAS TERMINALS	24
9.1 Instruction PP roof terminal:.....	25
10. APPENDIX: AIR INTAKE TERMINALS	26

1. WARNINGS AND DESIGN LIMITS

Read also the instructions at the attached drawings and act accordingly.

The flue gas system must be mounted free of tension.

Only the Muelink & Grol (M&G) of type Multiline and others in the appendix products mentioned in this manual must be used to make a certified design. **No other flue gas products are allowed.**

Check always the instructions on the website of the flue gas manufacturer, before installing:

https://www.mg-flues.com/wp-content/uploads/2016/10/Installation-instruction-Multiline-PP_Webversie_REV04.pdf

Always apply the horizontal (Dhor) and vertical (Dver) diameters according to table 2.1 and 3.1 and for air + flue according table 5.1 and 6.1.

The maximum length specified in the flue(+air) table includes “Elbow1”, an “Ls” of 1 meter and an increasing adapter piece when needed.

If “Ls” needs to be longer, one must take the extra length into account by deducting the equivalent from the maximum vertical length. Because Dhor is not always equal to Dver, the equivalent length needs to be determined according the following two situations:

1. When $D_{hor}=D_{ver}$: use the equivalent length table 4.1 and deduct the determined equivalent length from the maximum allowed vertical length in table 2.1, 3.1, 5.1 or 6.1.
2. When $D_{hor}<D_{ver}$: determine the equivalent vertical length according to the table below. Deduct the determined equivalent length from the maximum allowed vertical length in table 2.1, 3.1, 5.1 or 6.1.

Dhor [mm]	Dver [mm]	Equivalent length Ls [m/m]
150	200	1.0 m of Dhor equals 4.0 m Dver
200	250	1.0 m of Dhor equals 3.0 m Dver

The main flue gas piping system is built up behind Elbow1 and increasing adapter (if needed).

For further 45° and/or 90° elbows and horizontal lengths, the equivalent length table 2 shall also be used in this section. The mentioned horizontal pipe must have the same diameter as the vertical diameter because it is behind the increasing adapter in case Dhor and Dver differ. So do not determine the equivalent pipe length for horizontal pipes in this section as for extension of Ls.

See also the drawings in the appendix of chapter 8.

The sum of the total equivalent length of the components and horizontal pipe and vertical pipe may never exceed the maximum vertical length specified in table 2.1, 3.1, 5.1 or 6.1. for the specific boiler configuration.

After cutting pipes at the correct length make sure that the pipe end is deburred correctly to prevent damage to the pipe seal when mounting it.

The non-return valve is placed directly after the fan and has to be replaced once every 5 years during maintenance. During the life time of the installation the function and the state of the flue gas system must be checked annually. If there is any doubt if it functions correctly, or if it will keep functioning correctly within the coming period before the next annual check, defects or suspected future defects need to be solved.

For installation configurations that can't be designed using this instruction, the boiler manufacturer must be consulted for specific design instructions or system design calculations. Systems are/must be calculated according to guideline: “EN 13384 - Thermal and fluid dynamic calculation methods - part 2: Chimneys serving more than one heating appliance”.

If you need any advice in using this design instruction please contact the manufacturer.

1.1 Flue gas discharge areas

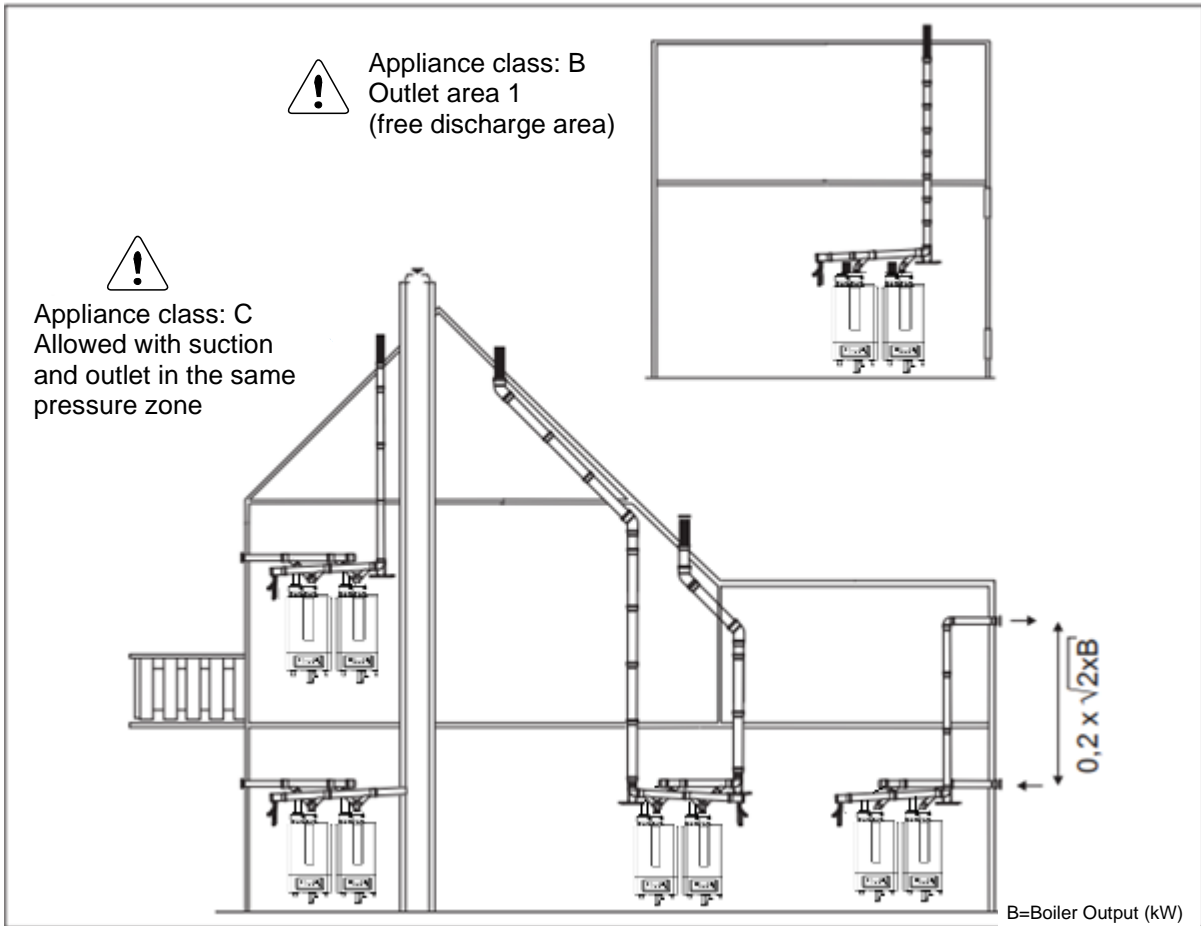

1.2 Parameter settings

The minimum fan speed of the CB-85 must be increased by 100 rpm. The other CB boilers don't need a parameter change for common flue.

1. From status screen, press MENU button once.
 2. Press UP/DOWN $\uparrow \downarrow$ to select "Settings" and press ENTER
 3. Press UP/DOWN $\uparrow \downarrow$ to select "Boiler Settings" and press ENTER
 4. Enter the installer password by pressing UP/DOWN $\uparrow \downarrow$ and LEFT \leftarrow and RIGHT \rightarrow and press ENTER
 5. Press UP/DOWN $\uparrow \downarrow$ to select "Boiler parameters" and press ENTER
 6. Press UP/DOWN $\uparrow \downarrow$ to select parameter "(93) Fan Speed Minimum" and press ENTER
 7. Press UP/DOWN $\uparrow \downarrow$ to adapt the fan speed according to the table and press ENTER
- To return to the status screen, press ESCAPE or MENU 4 times, or RESET once

Boiler model	Fan speed natural gas low	Fan speed LP gas low
CB 85	1800 \rightarrow 1900	1850 \rightarrow 1950
CB 105	No change	No change
CB 125	No change	No change
CB 155	No change	No change

2. PIPE DIMENSIONS IN-LINE-SYSTEMS FLUE GAS ONLY.

Table 2.1

Valid for PPs cascade flue system with internal Non Return Valve for the CB range (max. flue collector pressure 85 Pa)							
Collector System M&G: <ul style="list-style-type: none"> ▪ Collector diameters 150 and 200 mm ▪ Flue gas pipe diameters 150, 200 and 250 mm ▪ Junction connection 100 mm 45° swept 				maximum vertical lengths [m]: in line			
number of boilers	Boiler type	Nom. Input per boiler kW	total cascade capacity Nom. kW	Dhor.=150mm	Dhor.=150mm	Dhor.=200mm	Dhor.=200mm
				Dver.=150mm	Dver.=200mm	Dver.=200mm	Dver.=250mm
2	85	82	164	50	50	50	50
	105	97	194	50	50	50	50
	125	120	240	36	50	50	50
	155	145	290	5	50	50	50
3	85	82	246	32	50	50	50
	105	97	291	17	50	50	50
	125	120	360	4	50	50	50
	155	145	435	x	11	35	50
4	85	82	328	x	50	50	50
	105	97	388	x	50	50	50
	125	120	480	x	17	44	50
	155	145	580	x	x	2,5	48
5	85	82	410	x	10	44	60
	105	97	485	x	x	22	50
	125	120	600	x	x	6	50
	155	145	725	x	x	x	8
6	85	82	492	x	x	4	50
	105	97	582	x	x	x	37
	125	120	720	x	x	x	10
	155	145	870	x	x	x	x
7	85	82	574	x	x	x	24
	105	97	679	x	x	x	x
	125	120	840	x	x	x	x
	155	145	1015	x	x	x	x
8	85	82	656	x	x	x	x
	105	97	776	x	x	x	x
	125	120	960	x	x	x	x
	155	145	1160	x	x	x	x

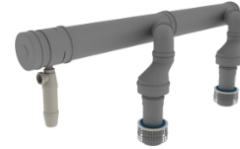

Note 1: The used collectors in this table are with 45° swept inlet on header.

Note 2: "x" means not possible

3. PIPE DIMENSIONS BACK-TO-BACK SYSTEMS FLUE ONLY .

Table 3.1

Valid for PPs cascade flue system with internal Non Return Valve for the CB range (max. flue collector pressure 85 Pa)							
Collector System M&G:				maximum vertical lengths [m]: back to back			
<ul style="list-style-type: none"> ▪ Collector diameters 150 and 200 mm ▪ Flue gas pipe diameters 150, 200 and 250 mm ▪ Junction connection 100 mm 45° swept 							
number of boilers	Boiler type	Nom. Input per boiler kW	total cascade capacity Nom. kW	Dhor= 200mm Dver.=200mm	Dhor= 200mm Dver.=250mm	Dhor.=2x 150mm Dver.=200mm	Dhor.=2x 150mm Dver.=250mm
2	85	82	164	50	50	50	50
	105	97	194	50	50	50	50
	125	120	240	50	50	50	50
	155	145	290	50	50	50	50
3	85	82	246	50	50	50	50
	105	97	291	50	50	50	50
	125	120	360	50	50	50	50
	155	145	435	35	50	50	50
4	85	82	328	50	50	50	50
	105	97	388	50	50	50	50
	125	120	480	44	50	50	50
	155	145	580	2,5	48	x	50
5	85	82	410	44	50	18	50
	105	97	485	22	50	6	50
	125	120	600	6	50	x	31
	155	145	725	x	8	x	x
6	85	82	492	4	50	4	50
	105	97	582	x	37	x	32
	125	120	720	x	10	x	8
	155	145	870	x	x	x	x
7	85	82	574	x	24	x	12
	105	97	679	x	x	x	6
	125	120	840	x	x	x	x
	155	145	1015	x	x	x	x
8	85	82	656	x	x	x	5
	105	97	776	x	x	x	x
	125	120	960	x	x	x	x
	155	145	1160	x	x	x	x

Note 1: The used collectors in this table are with 45° swept inlet on header.

Note 2: "x" means not possible

4. EQUIVALENT LENGTHS

Table 4.1

	150 mm	200 mm	250 mm
1m horizontal	1.0 m vertical	1.2 m vertical	1.3 m vertical
*45° elbow	1.7 m vertical	3.8 m vertical	5.9 m vertical
*90° elbow	4.0 m vertical	5.8 m vertical	8.2 m vertical

4.1 Example Equivalent lengths

We have 5 x CB85 boilers on a in line system 200mm horizontal and 200mm vertical. Total flue length is 34 meters. We use 2 elbows of 90° because we need to go an extra 4 meters horizontal.

Total vertical length =		30,0 m
Total horizontal length =	4 x 1,2	4,8 m
2 elbow 90° 200mm =	2 x 5,8	11,6 m
Total length to be taken in account =		<u>46,4 m</u> ⁺

When we look at table 2.1 the maximum flue length should be **44** meters so this installation does not comply.

As alternative you can use two elbows of 45° instead of 90° if the construction allow this.

Total vertical length =		30,0 m
Total horizontal length =	4 x 1,2	4,8 m
2 elbow 45° 200mm =	2 x 3,8	7,6 m
Total length to be taken in account =		<u>42,4 m</u> ⁺

5. PIPE DIMENSIONS FLUE+AIR INTAKE IN-LINE

Table 5.1

Valid for PPs cascade flue system with internal Non Return Valve for the CB range (max. flue collector pressure 85 Pa)							
Collector System M&G:				maximum vertical lengths [m]: in line Flue + Air inlet			
<ul style="list-style-type: none"> ▪ Collector diameters 150 and 200 mm ▪ Flue gas pipe diameters 150, 200 and 250 mm ▪ Junction connection 100 mm 45° swept 							
number of boilers	Boiler type	Nom. Input per boiler kW	total cascade capacity Nom. kW	Dhor.=150mm	Dhor.=150mm	Dhor.=200mm	Dhor.=200mm
				Dver.=150mm	Dver.=200mm	Dver.=200mm	Dver.=250mm
2	85	82	164	8+8	30+30	30+30	30+30
	105	97	194	4+4	30+30	30+30	30+30
	125	120	240	x	18+18	23+23	30+30
	155	145	290	x	x	x	12+12
3	85	82	246	x	20+20	27+27	30+30
	105	97	291	x	7+7	15+15	30+30
	125	120	360	x	x	4+4	30+30
	155	145	435	x	x	x	x
4	85	82	328	x	3+3	11+11	30+30
	105	97	388	x	x	4+4	30+30
	125	120	480	x	x	x	9+9
	155	145	580	x	x	x	x
5	85	82	410	x	4	3+3	29+29
	105	97	485	x	x	x	11+11
	125	120	600	x	x	x	x
	155	145	725	x	x	x	x
6	85	82	492	x	x	x	12+12
	105	97	582	x	x	x	x
	125	120	720	x	x	x	x
	155	145	870	x	x	x	x
7	85	82	574	x	x	x	2+2
	105	97	679	x	x	x	x
	125	120	840	x	x	x	x
	155	145	1015	x	x	x	x
8	85	82	656	x	x	x	x
	105	97	776	x	x	x	x
	125	120	960	x	x	x	x
	155	145	1160	x	x	x	x

Note 1: The used collectors in this table are with 45° swept inlet on header.

Note 2: "x" means not possible

6. PIPE DIMENSIONS FLUE+AIR INTAKE BACK TO BACK

Table 6.1

Valid for PPs cascade flue system with internal Non Return Valve for the CB range (max. flue collector pressure 85 Pa)							
Collector System M&G: <ul style="list-style-type: none"> ▪ Collector diameters 150 and 200 mm ▪ Flue gas pipe diameters 150, 200 and 250 mm ▪ Junction connection 100 mm 45° swept 				maximum vertical lengths [m]: back to back Flue + air inlet			
number of boilers	Boiler type	Nom. Input per boiler kW	total cascade capacity Nom. kW	Dhor= 200mm	Dhor= 200mm	Dhor.=2x 150mm	Dhor.=2x 150mm
				Dver=200mm	Dver.=250mm	Dver=200mm	Dver=250mm
2	85	82	164	30+30	30+30	30+30	30+30
	105	97	194	30+30	30+30	30+30	30+30
	125	120	240	23+23	30+30	30+30	30+30
	155	145	290	x	12+12	20+20	30+30
3	85	82	246	27+27	30+30	24+24	30+30
	105	97	291	15+15	30+30	11+11	30+30
	125	120	360	4+4	30+30	x	18+18
	155	145	435	x	x	x	x
4	85	82	328	11+11	30+30	9+9	30+30
	105	97	388	4+4	30+30	2+2	30+30
	125	120	480	x	9+9	x	18+18
	155	145	580	x	x	x	x
5	85	82	410	3+3	29+29	x	17+17
	105	97	485	x	11+11	x	x
	125	120	600	x	x	x	x
	155	145	725	x	x	x	x
6	85	82	492	x	12+12	x	2+2
	105	97	582	x	x	x	x
	125	120	720	x	x	x	x
	155	145	870	x	x	x	x
7	85	82	574	x	2+2	x	x
	105	97	679	x	x	x	x
	125	120	840	x	x	x	x
	155	145	1015	x	x	x	x
8	85	82	656	x	x	x	x
	105	97	776	x	x	x	x
	125	120	960	x	x	x	x
	155	145	1160	x	x	x	x

Note 1: The used collectors in this table are with 45° swept inlet on header.

Note 2: "x" means not possible

Important:

When using also common air intake use table 5.1 and 6.1 when air and flue pipes have almost the same length. If air intake is longer or shorter check table 5.1 and 6.1 if it is within the limits of the maximum length of flue outlet and air inlet. If not use a calculation factor of 1.3 between air and flue length. So when having 10 meter of air inlet transform this to 13 meter flue outlet pipe.

6.1 Example different length air intake and flue.

Having 4 CB 125 boilers on a back to back system with a 2 x 150mm collector and 250mm vertical pipe. Flue length is 25 meters and air intake is 14 meters. In table 6.1 maximum flue + air length is 18+18 meters. So the flue length is 7 meters to long but the air is 6 meters shorter. So we can multiply this by 1.3:

	Flue + Air
Maximum flue and air length =	18 + 18
Design of system =	25 + 14
Calculation total =	$-7 + (4 \times 1.3) = -1.8$ meter pipe

So this system complies.

When there are also extra bends use table 4.1 and take this length in to account.

7. Safety measures Common Flue Systems

In case CB boilers are installed with a common flue system and the combustion air is drawn directly from the room, safety measures have to be taken

Indicated hazard

The CB boilers are equipped with a Non-return valve to prevent recirculation of flue gas of a running boiler through one or more boilers which are not running and are connected with a common flue system. This Non-return valve might leak over time by pollution, incorrect maintenance or other unexpected cause. In case the combustion air is drawn from the room, flue gas might enter the room, which could lead to Carbon Monoxide (CO) poisoning.

Safety measures:

To cover this risk of Carbon Monoxide (CO) poisoning in combination with combustion air drawn directly from the room, two safety measures have to be taken:

1. Guaranteed sufficient outside air supply for combustion and ventilation according local standards, codes and regulations.
2. Use an CO detector for alarm and switching module to switch off all the boilers. The CO alarm system must be according national and local standards.

Additional Safety Advice

3. Use always the cascade manager of the boiler and check if power mode 2 is switched on. Power mode 2 is selected at parameter 148.
4. Combine all air intake terminals of the boilers, which do not necessarily have to be connected to the outside.

Ad 1. Guaranteed sufficient outside air supply for combustion and ventilation according local standards, codes and regulations.

The boiler-room must have sufficient outside air supply for combustion and ventilation. There are many ways of creating sufficient outside air supply, depending on location of the boiler-room in the building. The demands for the (size of the) boiler-room and required ventilation is prescribed in local standards, codes and regulations.

The execution and size of the outside air supply must be engineered and calculated by engineers thoroughly familiar with all aspects of the subject.

The outside air supply must be guaranteed during the lifetime of the installation. Risks of blocking or reducing the outside air supply, should be assessed and covered by this engineer and its design. Common obstacles in the outside air supply are e.g. Venting opening closed/reduced by pollution, a cupboard, a parked truck / car, closed for heat loss arguments, etc, etc.

Ad 2. CO detection and switch off module:

Use a CO detection system which has an alarming and switching module. Use a switching module that has an Normally Closed (N.C.) contact. The boiler safety loop will be extended with the CO detectors by connecting the N.C. contacts in series to the safety switch terminal connections 26/27 or 28/29 on the boiler to switch off the boiler in case of an alarm.

Remove the yellow wiring bridge and connect the N.C. contacts in series to the relay(s).

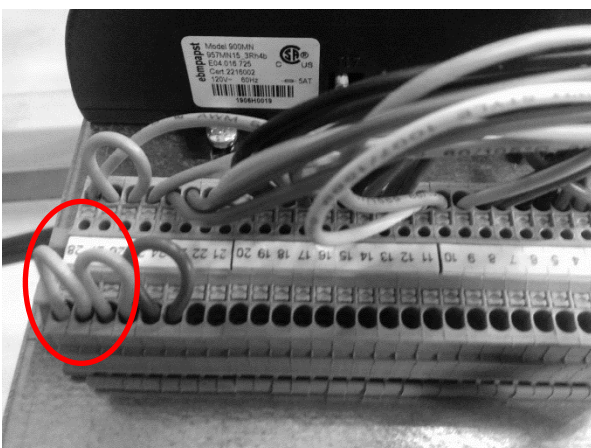

Low voltage connections CB boiler.

29	28	27	26	25	24	23	:
							-
Safety switch 2		Safety switch 1		Gas pressure switch		LWC Exter	

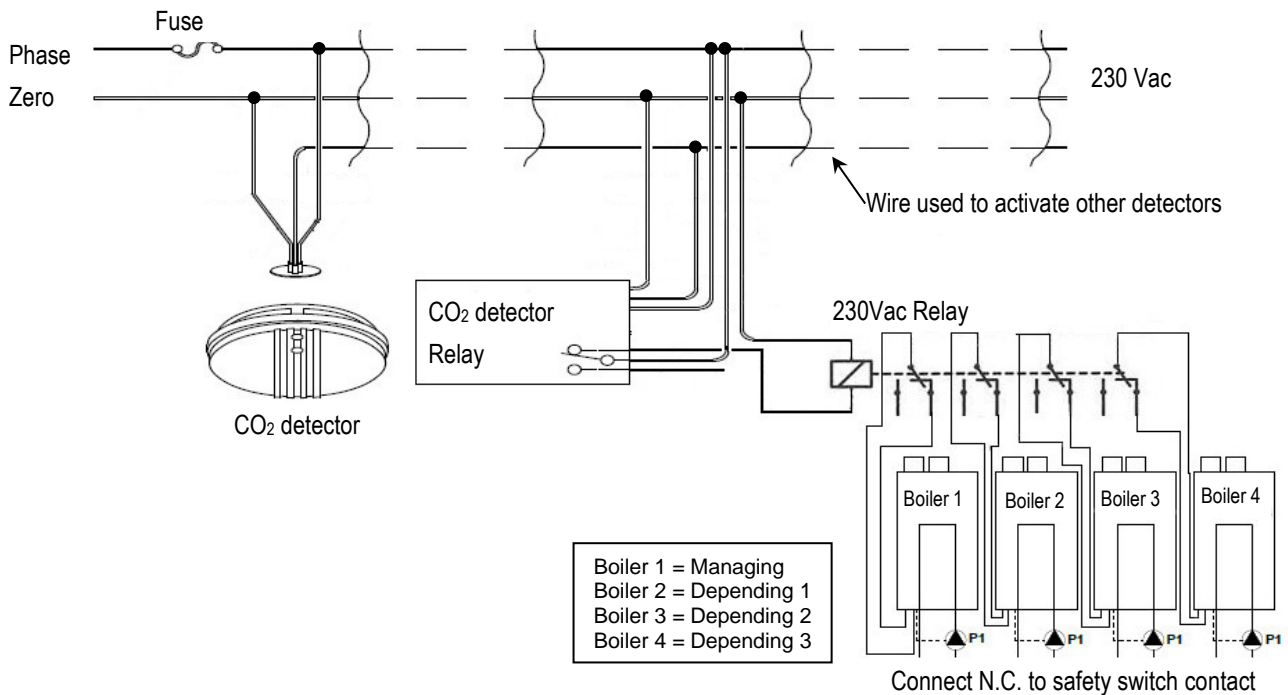

Use an extra 230V multipole relay (number of poles equal to number of boilers). In case of power failure on the CO alarm system and modules the boilers will shut down. Mount, install, test and maintain the CO detector according to the manufacturer's instructions. Test the system at least monthly, to ensure the boilers will switch off in case of a CO alarm.

In case of an CO alarm, the display of the boiler will mention: '*Max. thermostat lock error*'.

Ad 3. Use always the cascade manager of the boiler and check if power mode 2 is switched on (parameter 148)

Check parameter setting 148. This setting must be '*Power mode 2*'. Change the parameter 148 to '*Power mode 2*' in case the current setting is different.

See manual §: CASCADE – POWER BALANCE MODE

Several different power control modes can be selected to operate the cascade system.

- Power mode 0: Power control disabled; each boiler modulates based on the system setpoint.
- ~~Power mode 1: Power control algorithm to have a minimum number of boilers/boilers active.~~
- Power mode 2: Power control algorithm to have a maximum number of boilers/boilers active.
- Power mode 3: Power control algorithm to have a balanced number of boilers/boilers active.

Ad 4. Combine all air intake terminals of the boilers

Combine all air intake terminals of the boiler, which do not necessarily have to be connected to the outside of the room. The purpose of a combined air intake is to have a controlled airflow towards the boilers and improve the air exchange in the room.

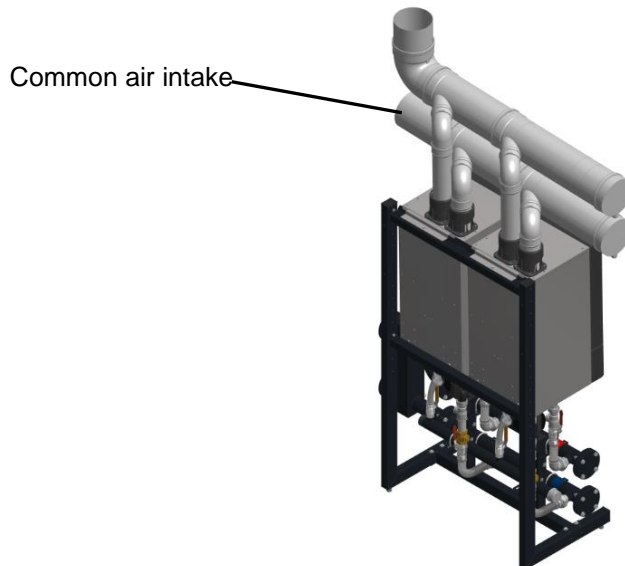

7.1 Existing common venting guidelines.

Do not common vent the CB boiler with the vent pipe of any other boiler or appliance. However, when an existing boiler is removed from an existing common venting system, the common venting system is likely to be too large for proper venting of the appliances remaining connected to it. At the time of removal of an existing boiler, the following steps shall be followed with each appliance remaining connected to the common venting system placed in operation, while the other appliances remaining connected to the common venting system are not in operation:

- 1) Seal any unused openings in the common venting system.
- 2) Visually inspect the venting system for proper size and horizontal pitch and determine there is no blockage or restriction, leakage, corrosion and other deficiencies which could cause an unsafe condition.
- 3) Insofar as is practical, close all building doors and windows and all doors between the space in which the appliances remaining connected to the common venting system are located and other spaces of the building. Turn on clothes dryers and any appliance not connected to the common venting system. Turn on any exhaust fans, such as range hoods and bathroom exhausts, so they will operate at maximum speed. Do not operate a summer exhaust fan. Close fireplace dampers.
- 4) Place in operation the appliance being inspected. Follow the lighting instructions. Adjust thermostat so appliance will operate continuously.
- 5) Test for spillage at the draft hood relief opening after 5 minutes of main burner operation. Use the flame of a match or candle, or smoke from a cigarette, cigar, or pipe.
- 6) After it has been determined that each appliance remaining connected to the common venting system properly vents when tested as outlined above, return doors, windows, exhaust fans, fireplace dampers and any other gas-burning appliance to their previous condition of use.

Any improper operation of the common venting system must be corrected so the installation conforms with the National standards.

When resizing any portion of the common venting system, the common venting system must be resized to approach the minimum size as determined using the appropriate tables in the Standards and this manual.

8. APPENDIX: Design instruction flue gas system

8.1 Twin pipe in-line CB 85-125

COMMERCIAL BOILER
TWIN PIPE/PARALLEL FLUE GAS AND AIR SUPPLY CONNECTION
INSTALLATION DESIGN INSTRUCTIONS FOR
COMMON FLUE SYSTEM WITH RETURN VALVE

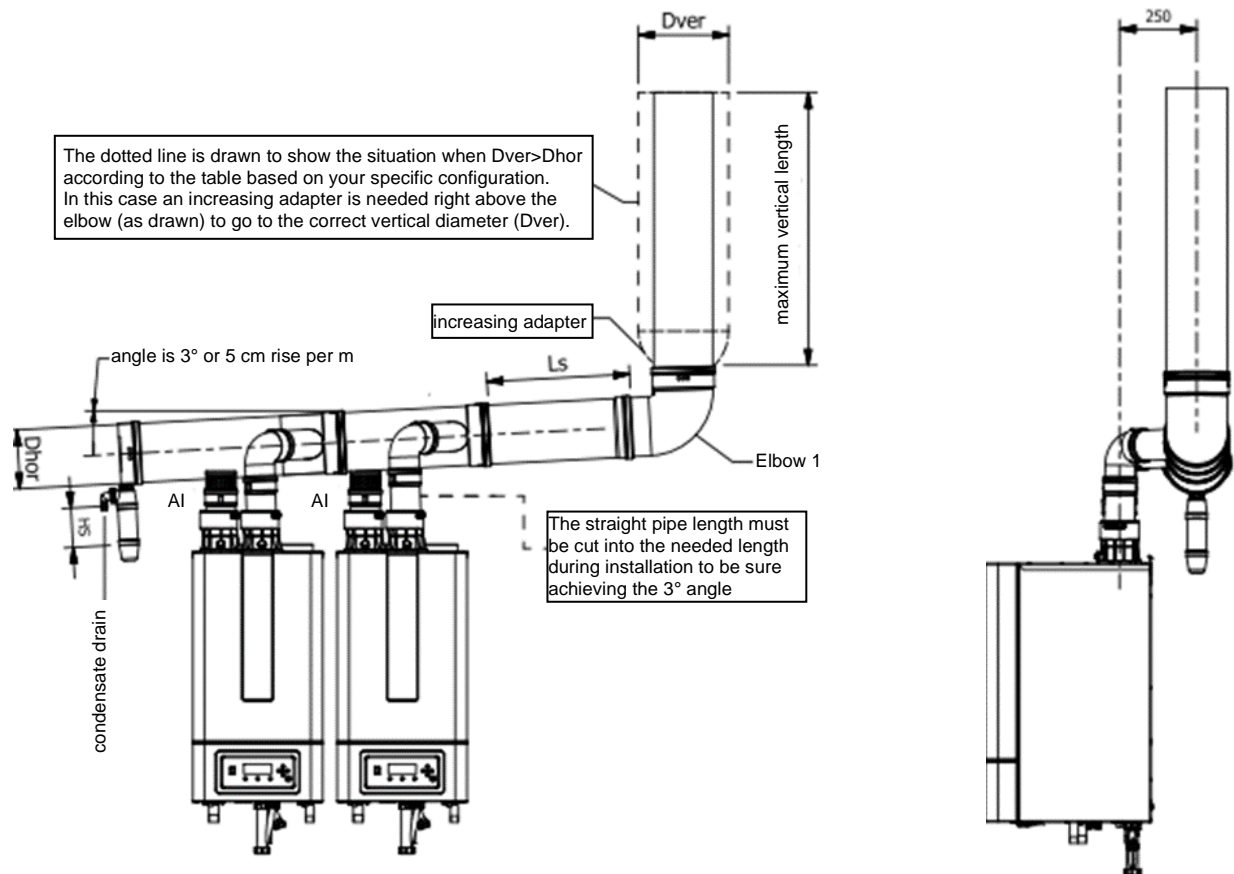
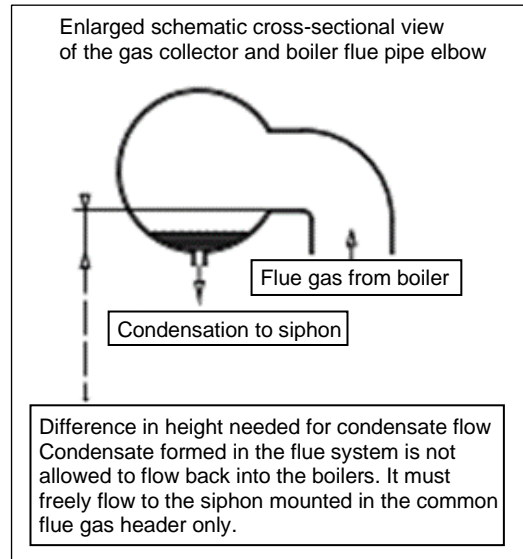
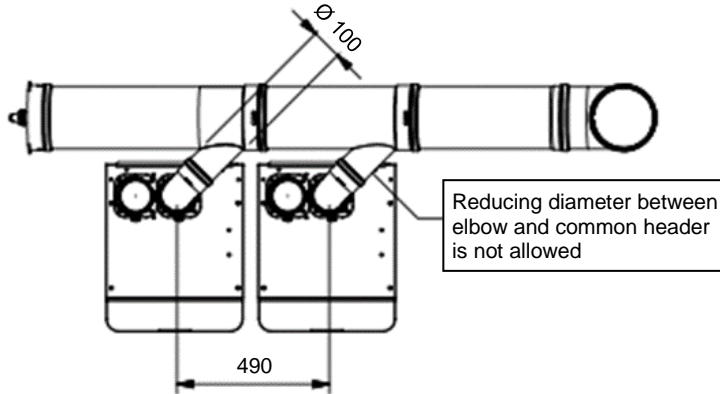

- Two boilers are used as an example, but the principle is applicable to other boiler amounts
- For detailed model dimensions we refer to the boiler manual

Ls = The length of straight horizontal pipe right after the last collector pipe closest to the common flue gas exit channel (mm)
 Dh or = The outer diameter of the horizontal flue gas collector (mm).
 Dver = The outer diameter of the vertical common flue gas pipe (mm).
 AI = Combustion Air Inlet
 SH = Siphon height.

8.2 Concentric in-line CB 85-125

COMMERCIAL BOILER CONCENTRIC FLUE GAS AND AIR SUPPLY CONNECTION INSTALLATION DESIGN INSTRUCTIONS FOR COMMON FLUE SYSTEM WITH RETURN VALVE

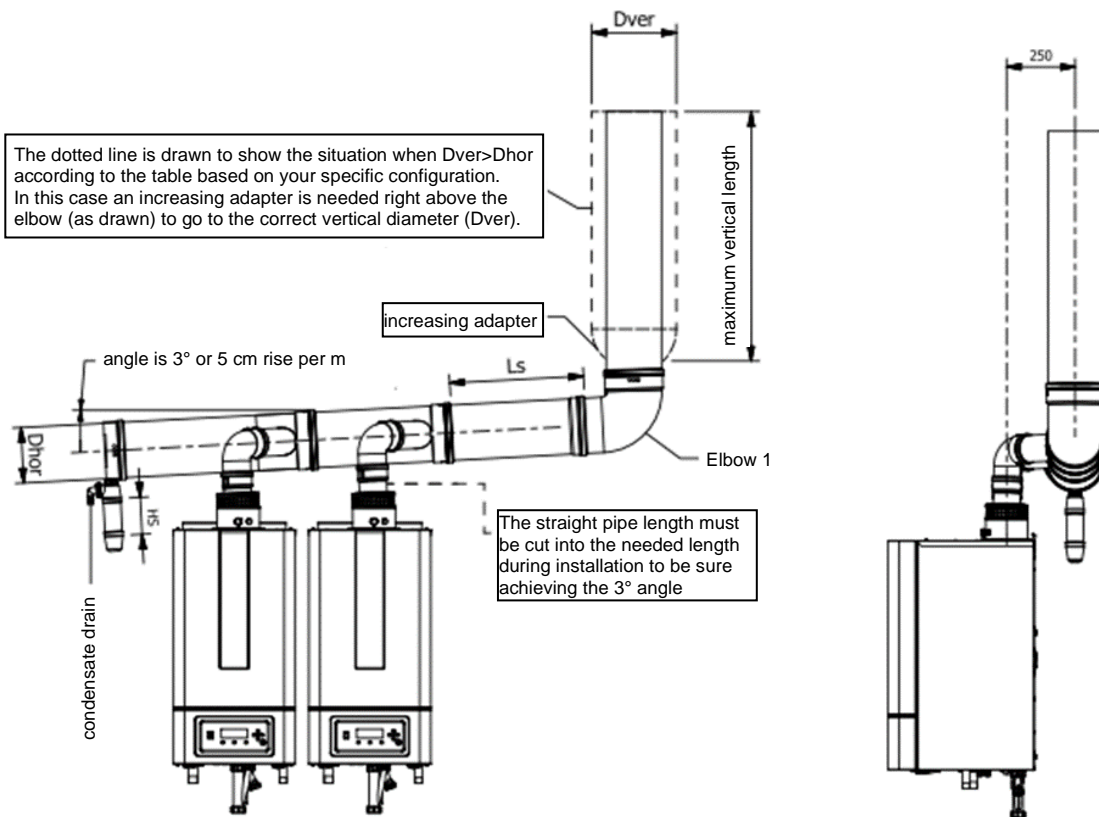
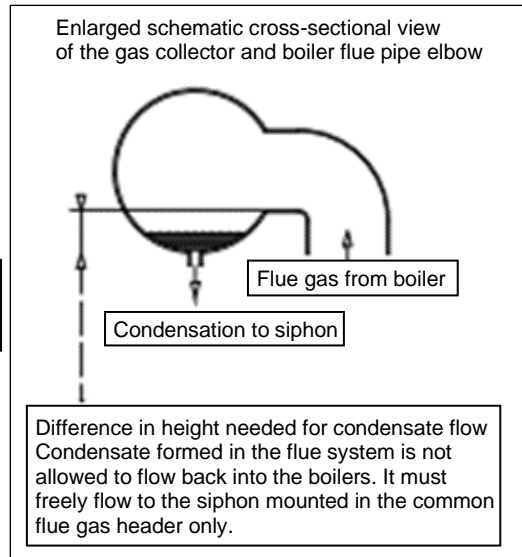
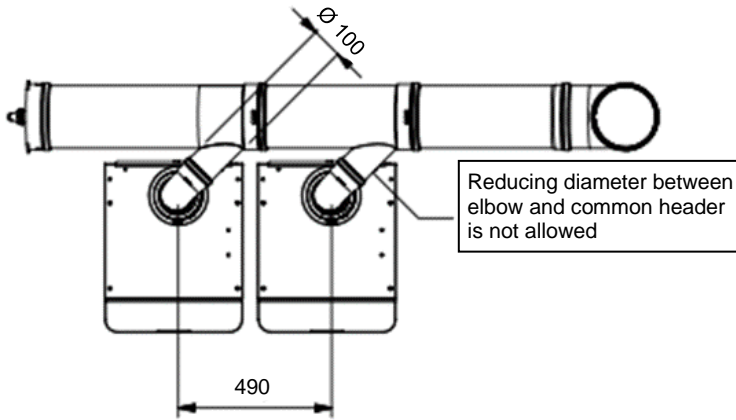

- Two boilers are used as an example, but the principle is applicable to other boiler amounts
- For detailed model dimensions we refer to the boiler manual

L_s = The length of straight horizontal pipe right after the last collector pipe closest to the common flue gas exit channel (mm)
 D_{hor} = The outer diameter of the horizontal flue gas collector (mm).
 D_{ver} = The outer diameter of the vertical common flue gas pipe (mm).
 AI = Combustion Air Inlet
 SH = Siphon height.

8.3 Twin pipe in-line CB 155

**COMMERCIAL BOILER
TWIN PIPE/PARALLEL FLUE GAS AND AIR SUPPLY CONNECTION
INSTALLATION DESIGN INSTRUCTIONS FOR
COMMON FLUE SYSTEM WITH RETURN VALVE**

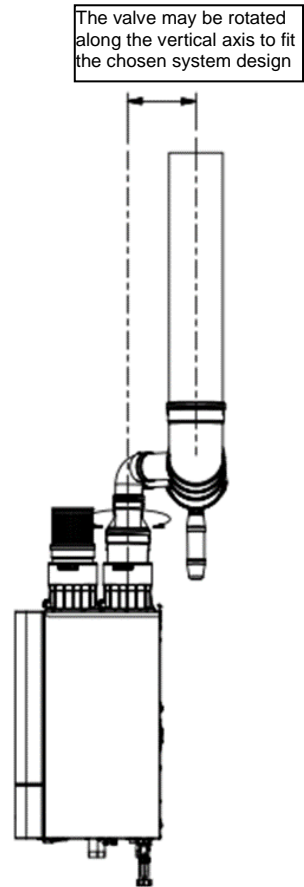
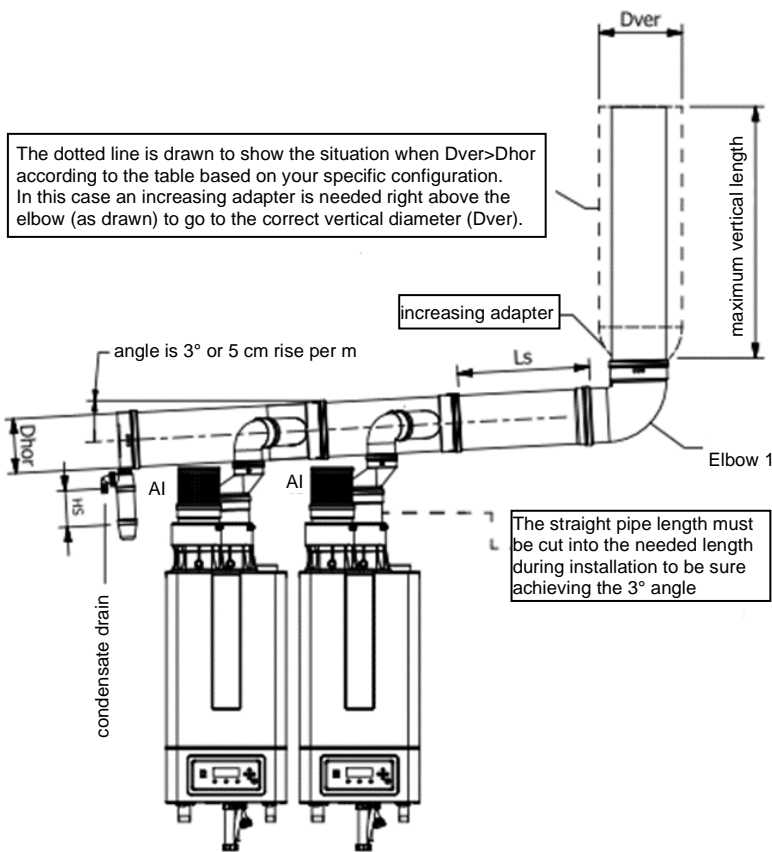
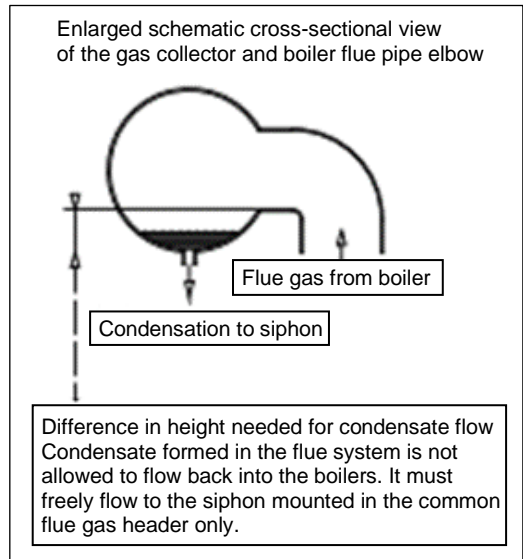
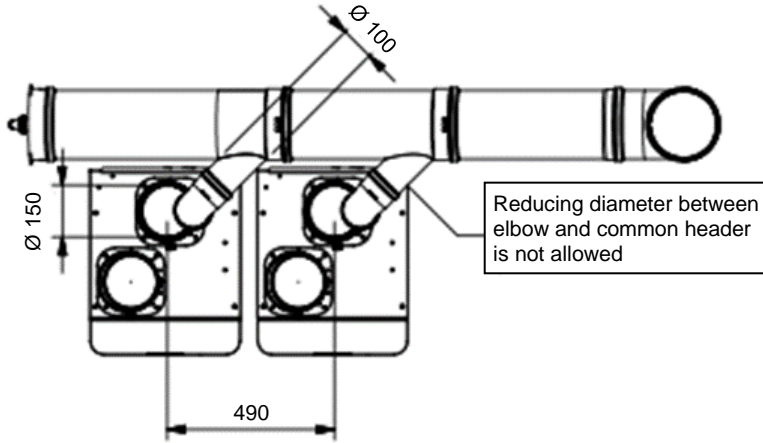

- Two boilers are used as an example, but the principle is applicable to other boiler amounts
- For detailed model dimensions we refer to the boiler manual

Ls = The length of straight horizontal pipe right after the last collector pipe closest to the common flue gas exit channel (mm)
 Dhor = The outer diameter of the horizontal flue gas collector (mm).
 Dver = The outer diameter of the vertical common flue gas pipe (mm).
 AI = Combustion Air Inlet
 SH = Siphon height.

8.4 Twin pipe back to back on one collector CB 85-125

COMMERCIAL BOILER
TWIN PIPE/PARALLEL FLUE GAS AND AIR SUPPLY CONNECTION
INSTALLATION DESIGN INSTRUCTIONS FOR
COMMON FLUE SYSTEM WITH RETURN VALVE

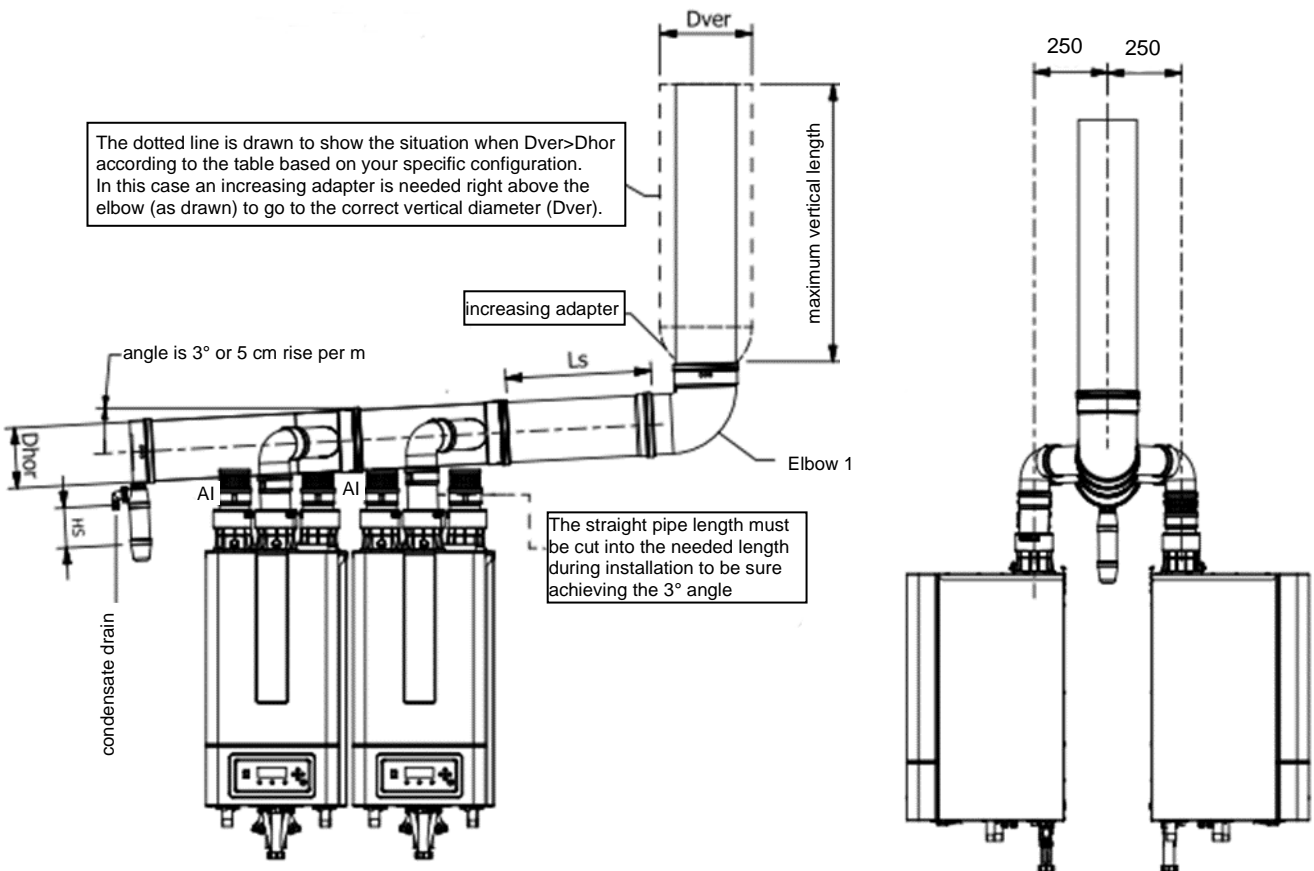
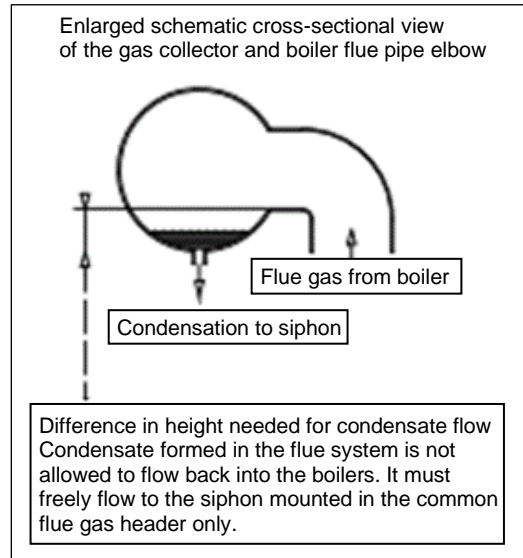
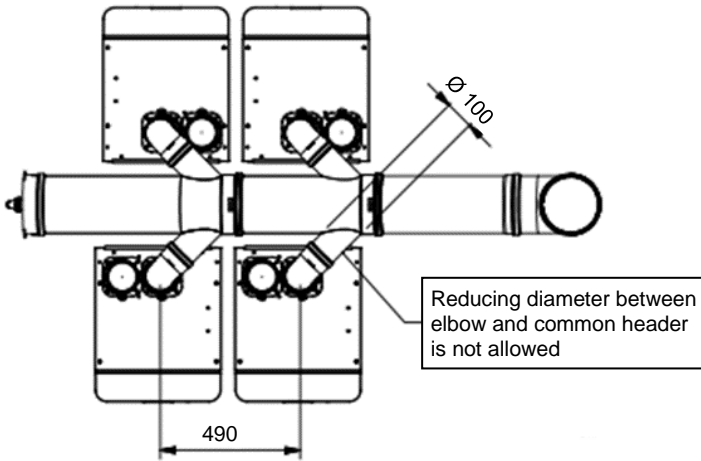

- Four boilers are used as an example, but the principle is applicable to other boiler amounts
- For detailed model dimensions we refer to the boiler manual

Ls = The length of straight horizontal pipe right after the last collector pipe closest to the common flue gas exit channel (mm)
Dhor = The outer diameter of the horizontal flue gas collector (mm).
Dver = The outer diameter of the vertical common flue gas pipe (mm).
AI = Combustion Air Inlet
SH = Siphon height.

8.5 Concentric back to back on one collector CB 85-125

COMMERCIAL BOILER CONCENTRIC FLUE GAS AND AIR SUPPLY CONNECTION INSTALLATION DESIGN INSTRUCTIONS FOR COMMON FLUE SYSTEM WITH RETURN VALVE

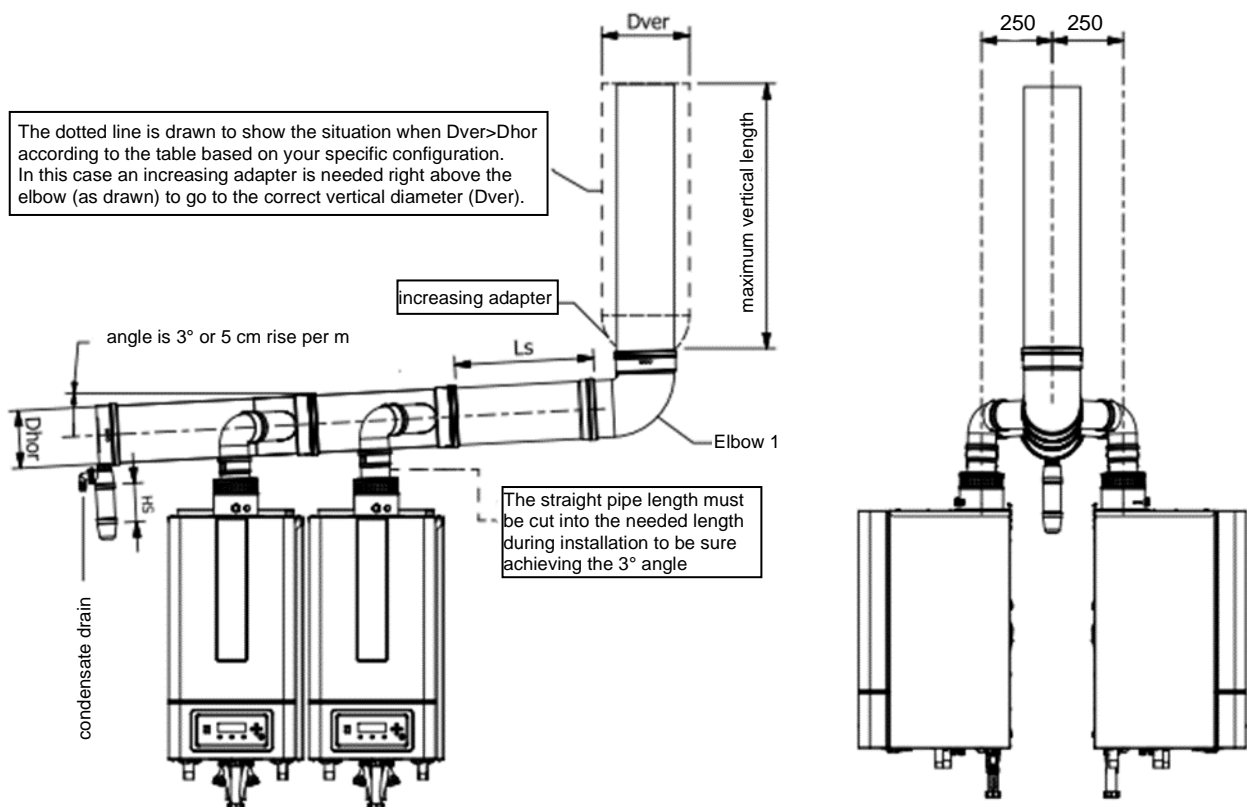
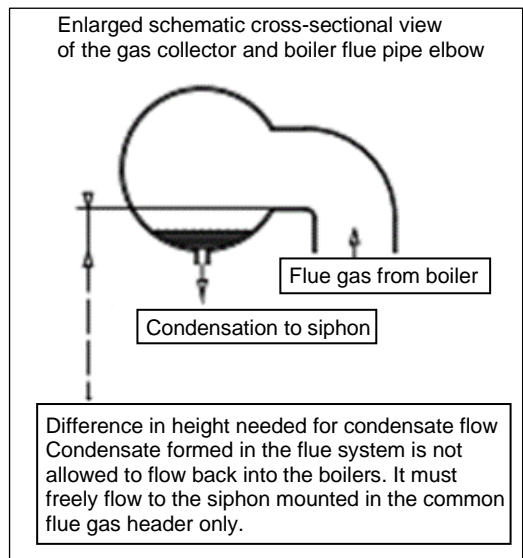
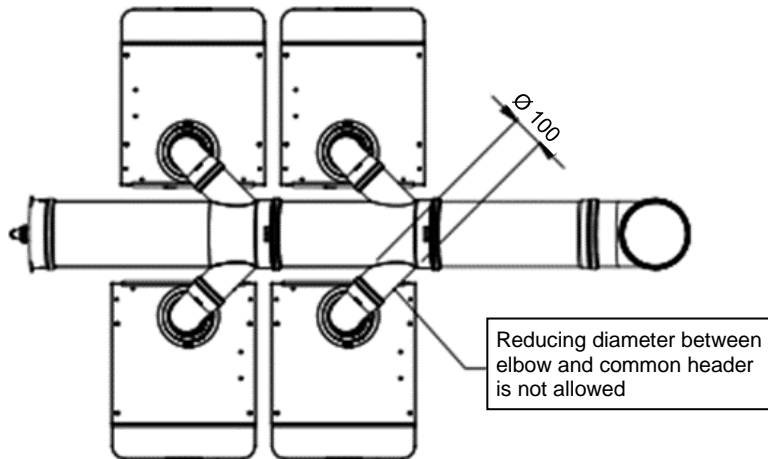

- Two boilers are used as an example, but the principle is applicable to other boiler amounts
- For detailed model dimensions we refer to the boiler manual

L_s = The length of straight horizontal pipe right after the last collector pipe closest to the common flue gas exit channel (mm)
 D_{hor} = The outer diameter of the horizontal flue gas collector (mm).
 D_{ver} = The outer diameter of the vertical common flue gas pipe (mm).
 AI = Combustion Air Inlet
 SH = Siphon height.

8.6 Twin pipe back to back on one collector CB 155

COMMERCIAL BOILER
TWIN PIPE/PARALLEL FLUE GAS AND AIR SUPPLY CONNECTION
INSTALLATION DESIGN INSTRUCTIONS FOR
COMMON FLUE SYSTEM WITH RETURN VALVE

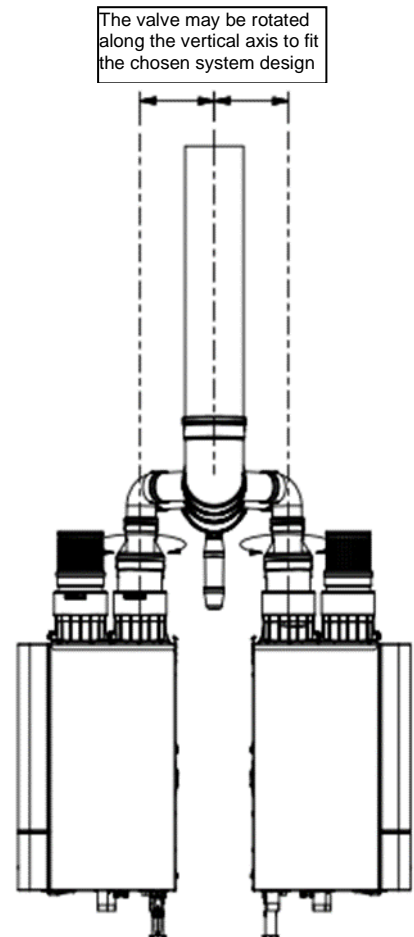
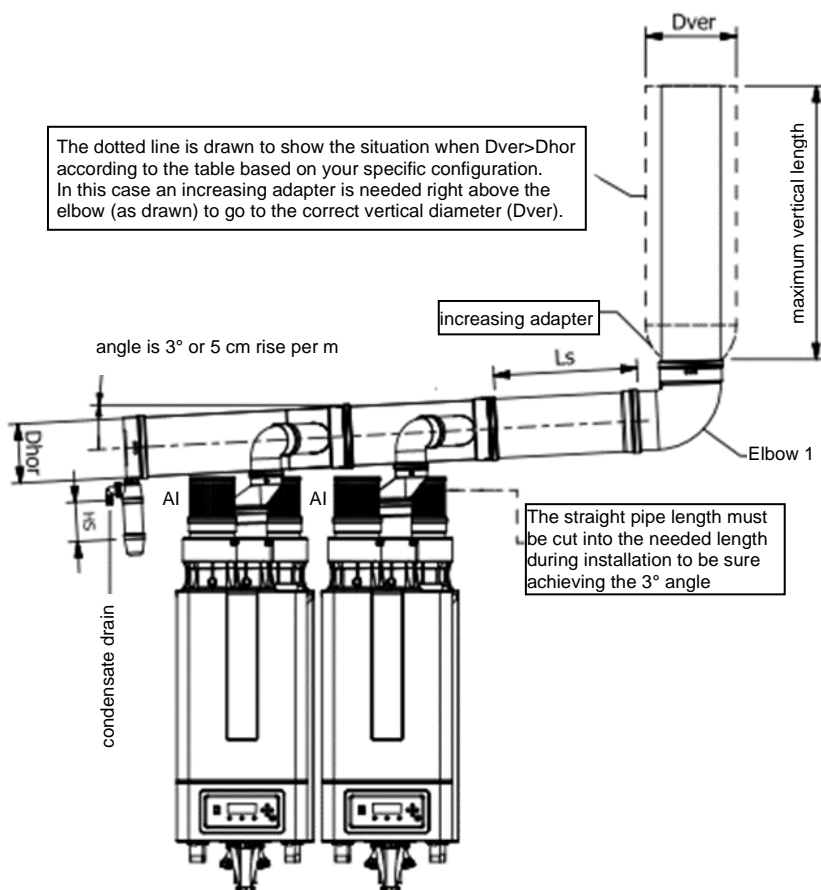
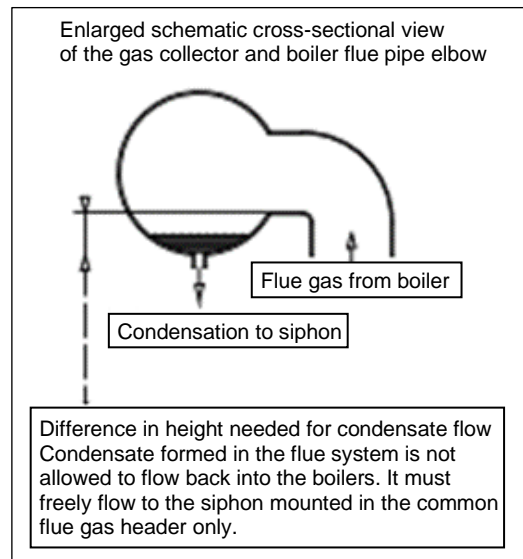
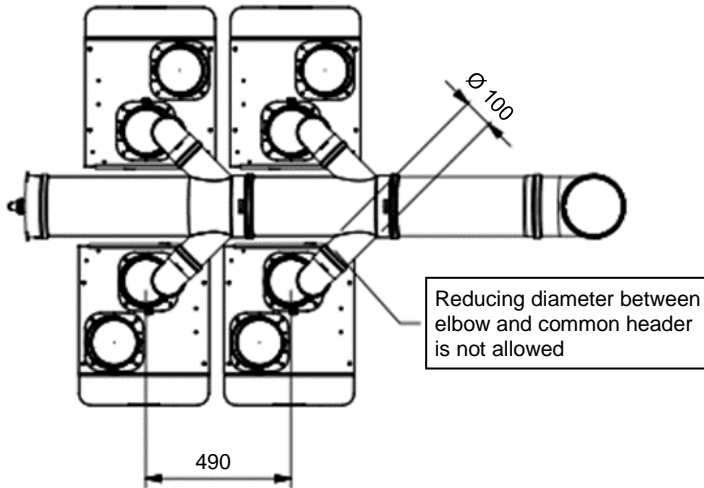

- Four boilers are used as an example, but the principle is applicable to other boiler amounts
- For detailed model dimensions we refer to the boiler manual

L_s = The length of straight horizontal pipe right after the last collector pipe closest to the common flue gas exit channel (mm)
 D_{hor} = The outer diameter of the horizontal flue gas collector (mm).
 D_{ver} = The outer diameter of the vertical common flue gas pipe (mm).
 AI = Combustion Air Inlet
 SH = Siphon height.

8.7 Twin pipe back to back on two collectors CB 85-125

COMMERCIAL BOILER
TWIN PIPE/PARALLEL FLUE GAS AND AIR SUPPLY CONNECTION
INSTALLATION DESIGN INSTRUCTIONS FOR
COMMON FLUE SYSTEM WITH RETURN VALVE

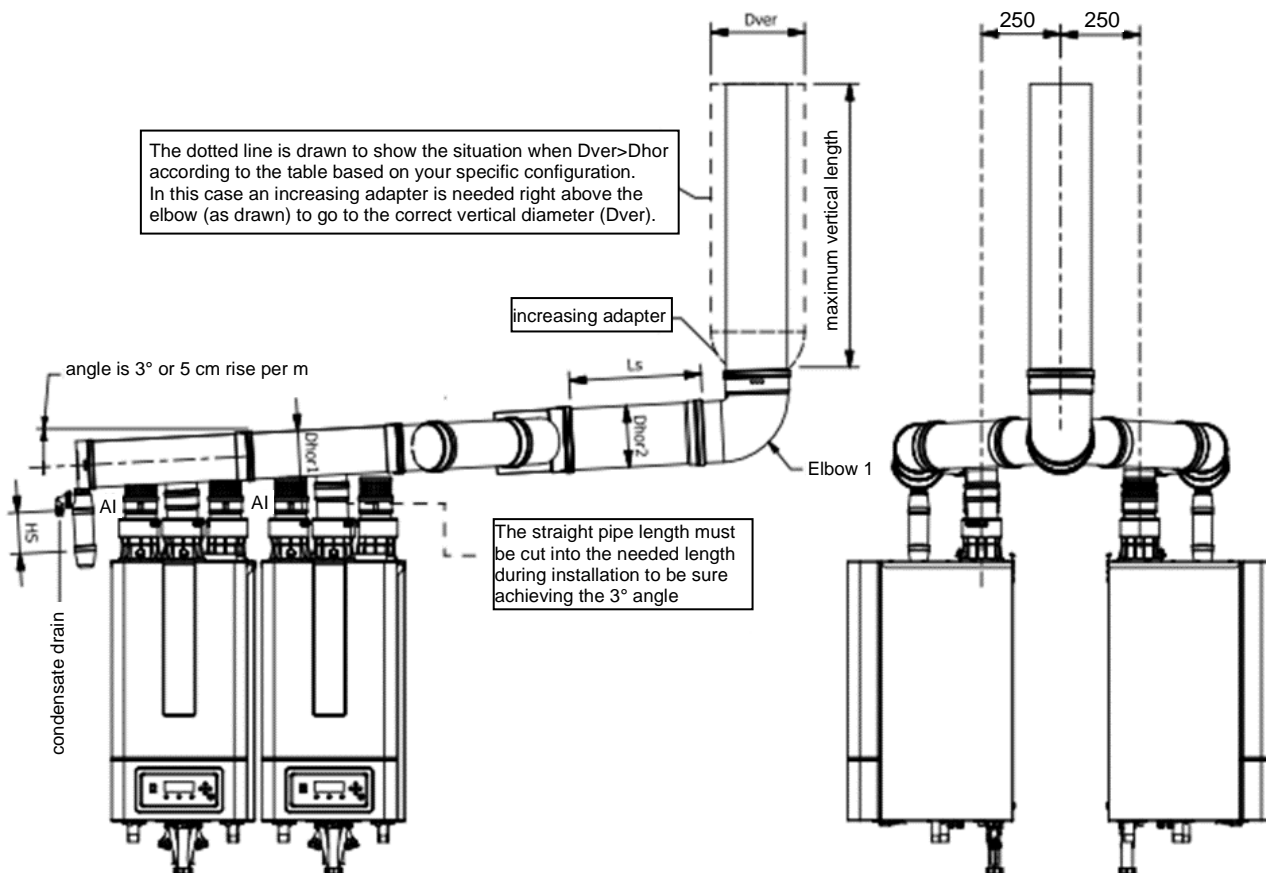
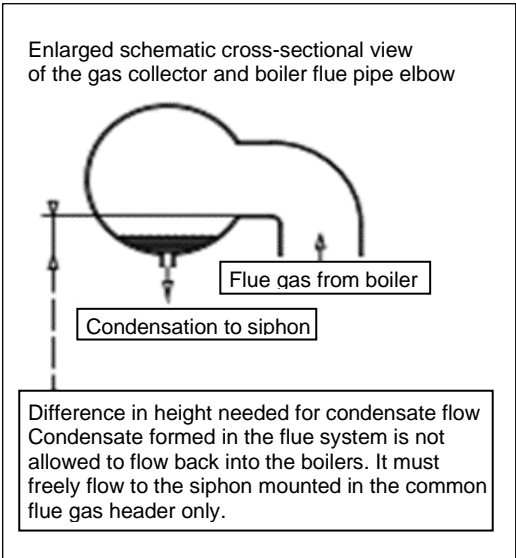
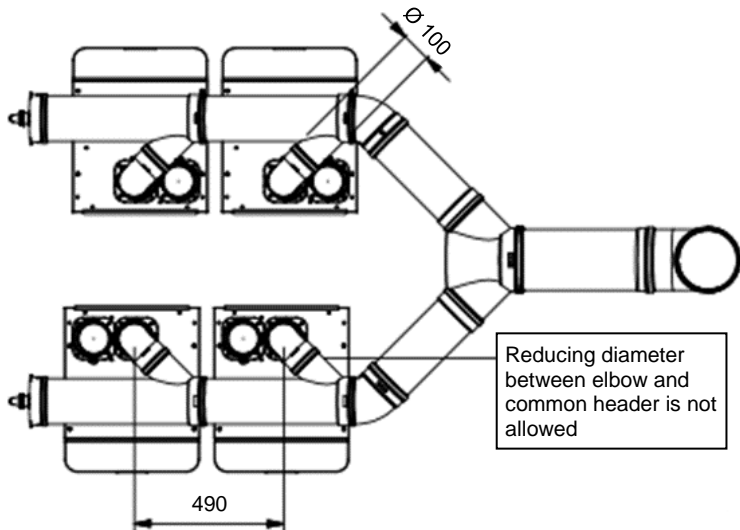

- Four boilers are used as an example, but the principle is applicable to other boiler amounts
- For detailed model dimensions we refer to the boiler manual

Ls = The length of straight horizontal pipe right after the last collector pipe closest to the common flue gas exit channel (mm)
 Dhor = The outer diameter of the horizontal flue gas collector (mm).
 Dver = The outer diameter of the vertical common flue gas pipe (mm).
 AI = Combustion Air Inlet
 SH = Siphon height.

8.8 Concentric back to back on two collectors CB 85-125

COMMERCIAL BOILER
 CONCENTRIC FLUE GAS AND AIR SUPPLY CONNECTION
 INSTALLATION DESIGN INSTRUCTIONS FOR
 COMMON FLUE SYSTEM WITH RETURN VALVE

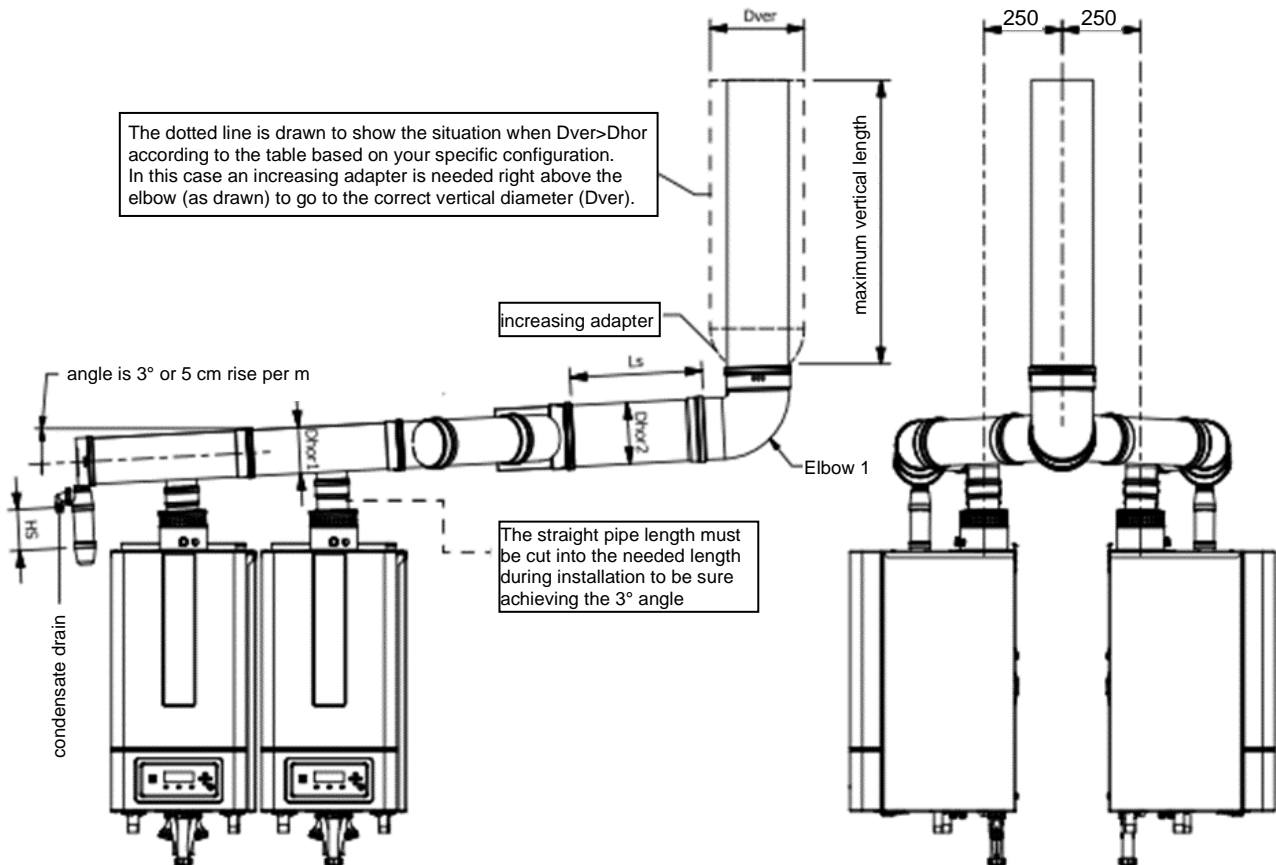
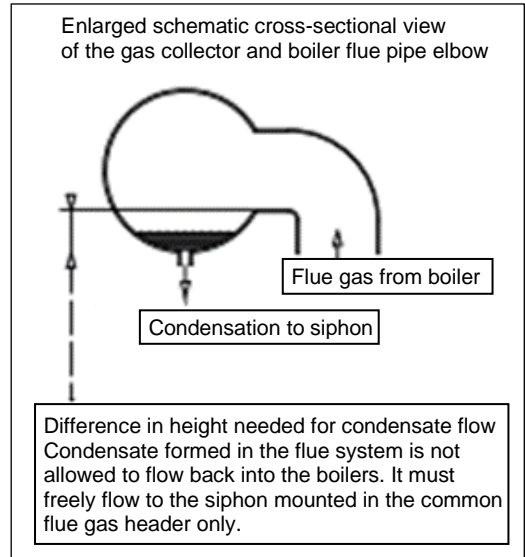
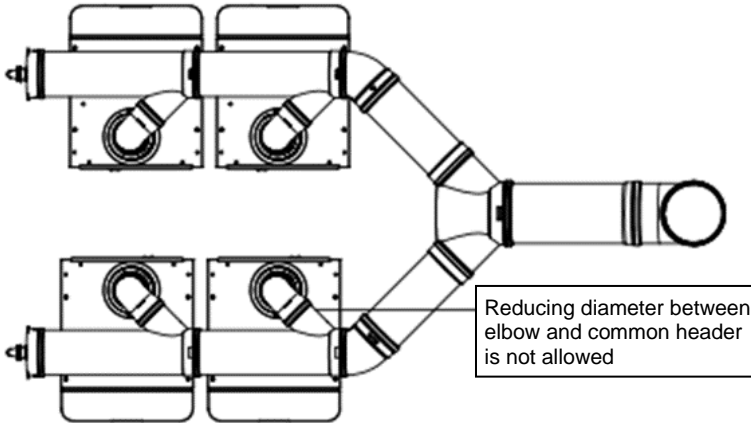

- Two boilers are used as an example, but the principle is applicable to other boiler amounts
- For detailed model dimensions we refer to the boiler manual

Ls = The length of straight horizontal pipe right after the last collector pipe closest to the common flue gas exit channel (mm)
 Dhor = The outer diameter of the horizontal flue gas collector (mm).
 Dver = The outer diameter of the vertical common flue gas pipe (mm).
 AI = Combustion Air Inlet
 SH = Siphon height.

8.9 Twin pipe back to back on two collectors CB 155

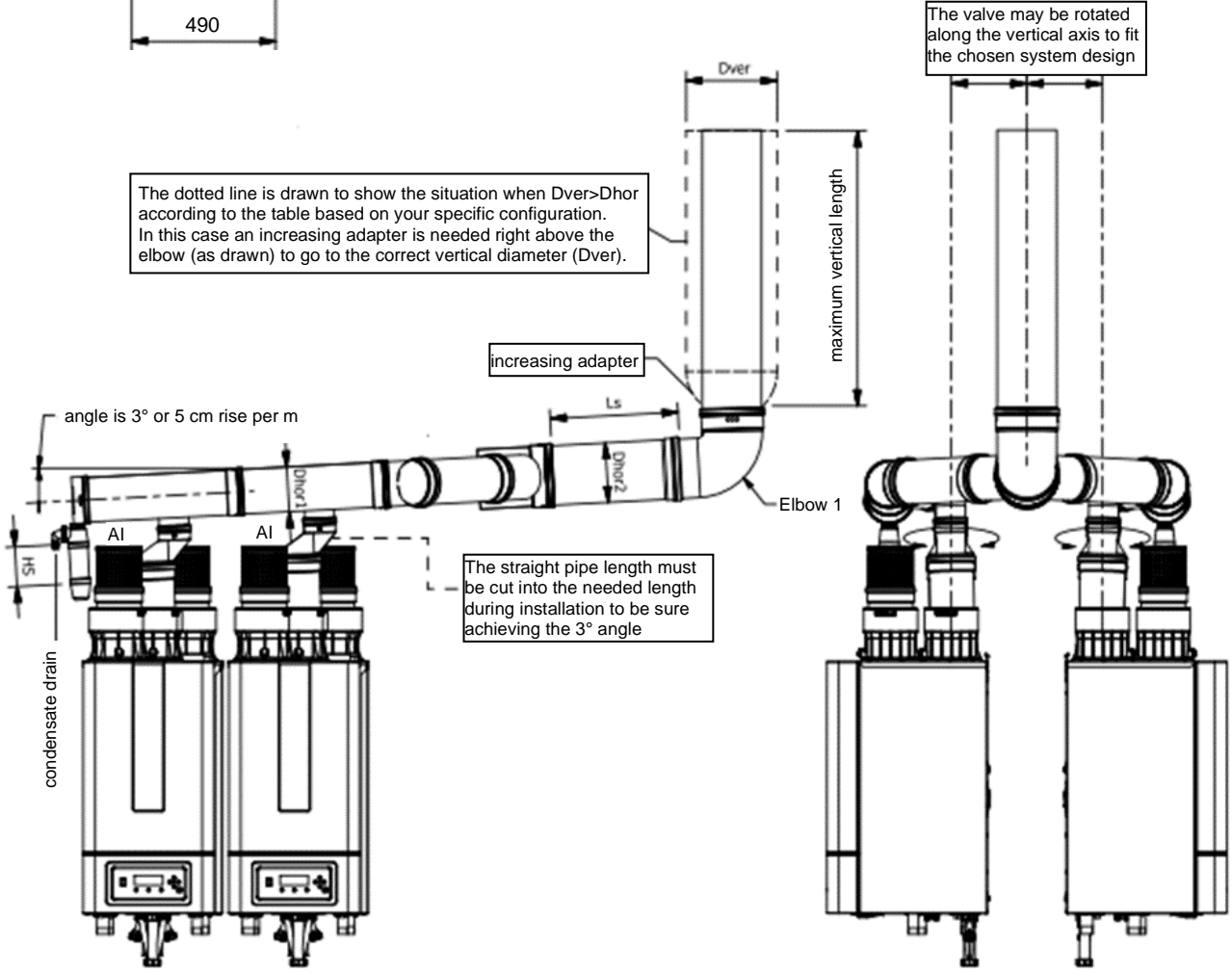
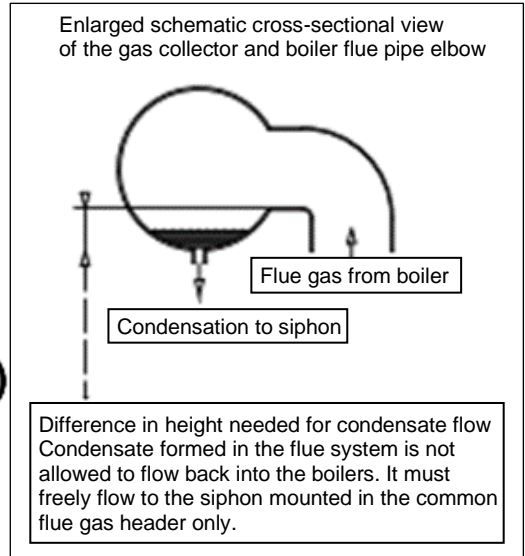
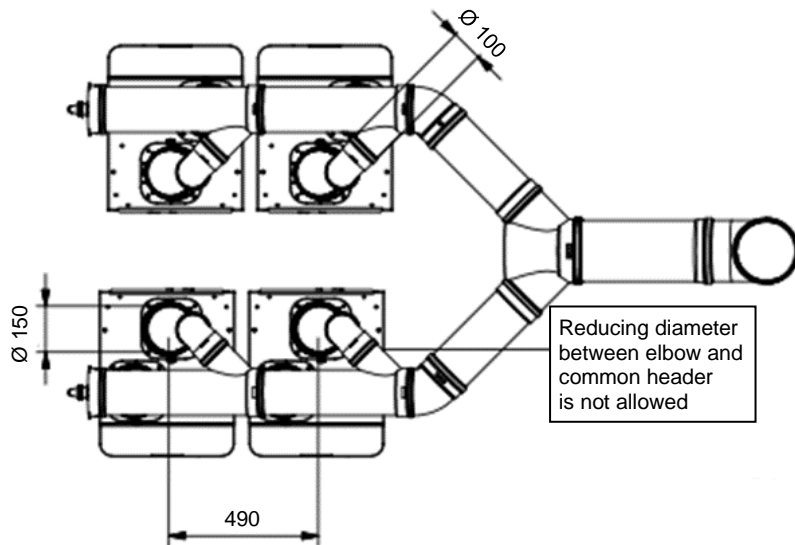

COMMERCIAL BOILER
TWIN PIPE/PARALLEL FLUE GAS AND AIR SUPPLY CONNECTION
INSTALLATION DESIGN INSTRUCTIONS FOR
COMMON FLUE SYSTEM WITH RETURN VALVE



- Four boilers are used as an example, but the principle is applicable to other boiler amounts
- For detailed model dimensions we refer to the boiler manual

L_s = The length of straight horizontal pipe right after the last collector pipe closest to the common flue gas exit channel (mm)
 D_{hor} = The outer diameter of the horizontal flue gas collector (mm).
 D_{ver} = The outer diameter of the vertical common flue gas pipe (mm).
 AI = Combustion Air Inlet
 SH = Siphon height.

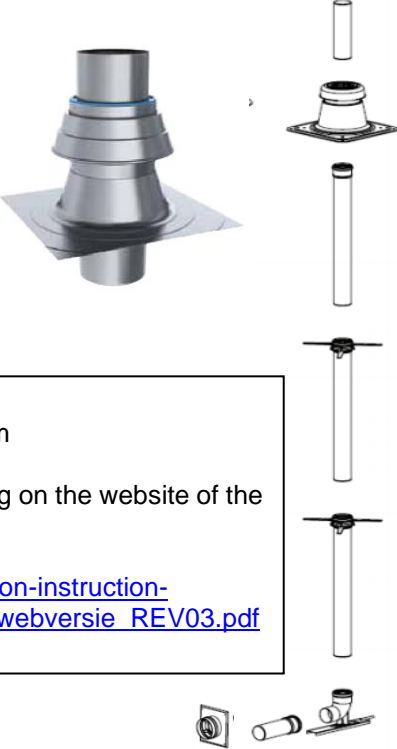
9. APPENDIX: Flue gas terminals

 <p>Chimney-caps with air intake: For diameters 150mm and 200mm</p> <p>Check instructions before installing on the website of the flue gas manufacturer: https://www.mg-flues.com/wp-content/uploads/2019/07/Installation-instruction-Schoorsteenoplossing-Flex-Star_webversie_REV03.pdf</p>	 <p>PP roof terminal For diameters 150mm and 200mm</p>
---	---

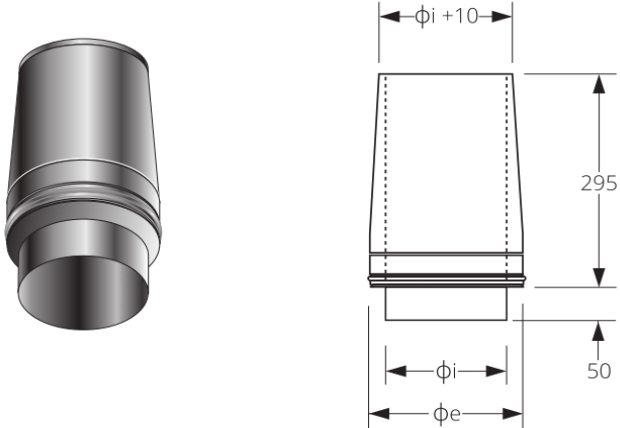
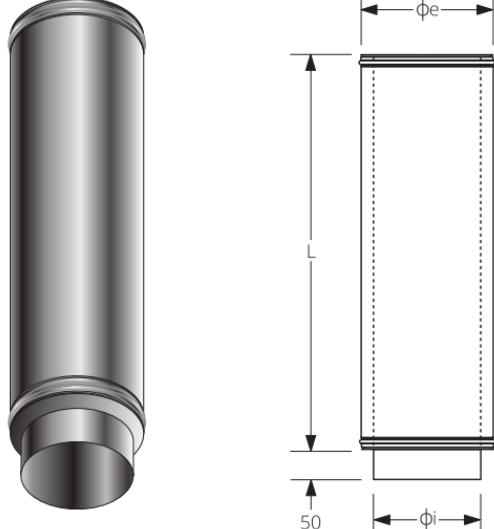
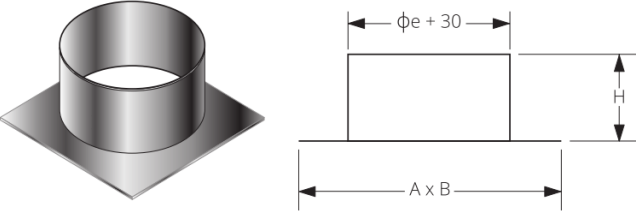
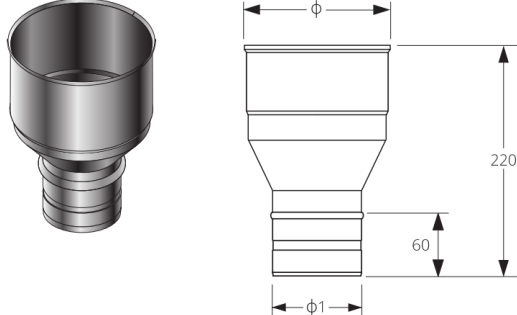
<p>Flue gas terminal 150/200/250mm</p>  <p>Finish cone stainless steel 250mm</p>	<p>Straight element 150/200/250mm</p> 
<p>Flat roof flashing 150/200/250mm</p> 	<p>Increasing adapter 200-250mm</p> 
<p>Check instructions before installing on the website of the flue gas manufacturer: http://wordpress-252472-827897.cloudwaysapps.com/wp-content/uploads/2018/10/BURGERHOUT-ROCCHEGGIANI-LR.pdf</p>	

9.1 Instruction PP roof terminal:

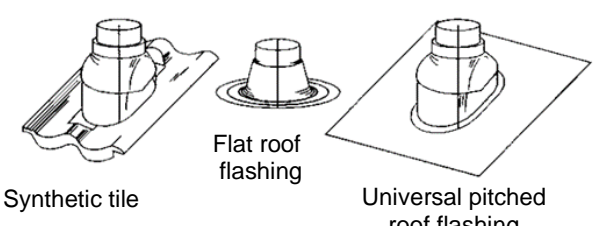
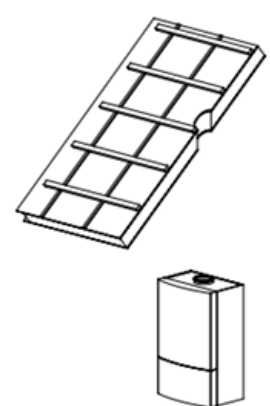
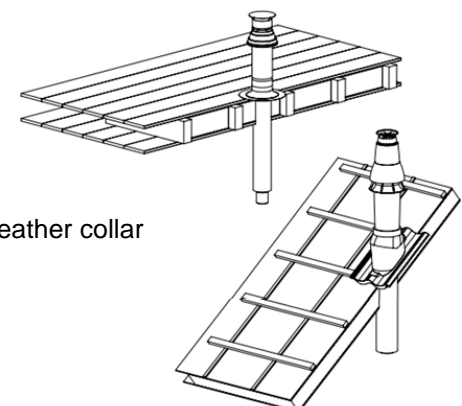
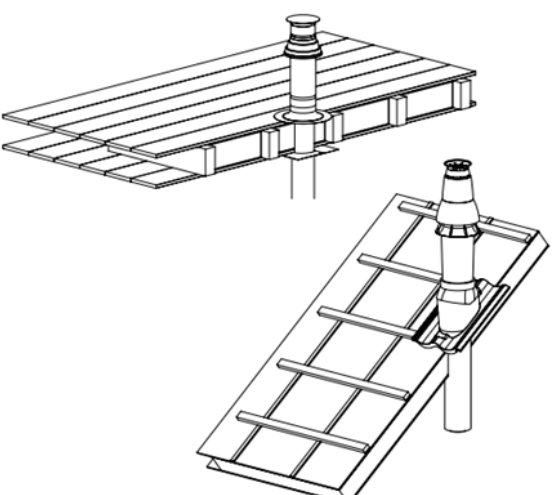
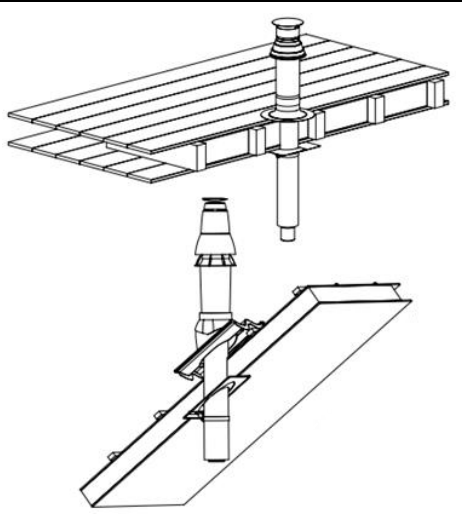
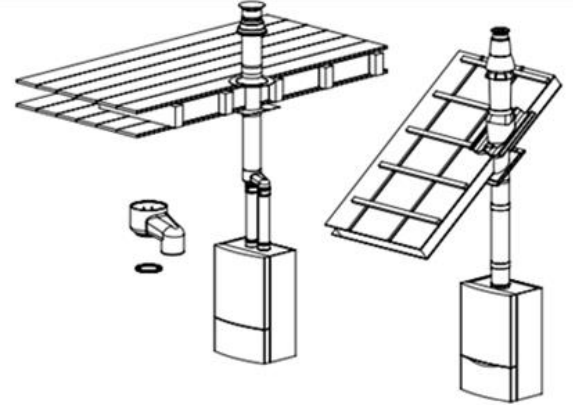
<p>1. Check the flue terminal on any damage</p>  <p>Synthetic tile Flat roof flashing Universal pitched roof flashing</p>	<p>2. Taking the roofing into account, determine the type of weather collar synthetic file or universal pitched roof flashing; for a flat roof an aluminium flat roof flashing.</p> <p>3. Determine where the flue terminal will be positioned. With a tile roof use the universal pitched roof flashing</p>
 <p>4. Make a hole for the flue terminal from the outside. Ensure that no saw dust or other dust gets into the boiler</p>	 <p>5. Fit the weather collar</p>
 <p>6. Carefully insert the flue terminal through the roof from the outside. Attention: do not twist the cap</p>	 <p>7. Put the flue terminal into a vertical position using an air level. (If desired, cover plates, to be supplied separately, can be fitted).</p>
 <p>8. Fix the supplied wall clamp round the flue terminal and fit it to the roof construction. Do not tighten the clamp yet.</p>	<p>9. Depending on the type of terminal, concentric or twin pipe, the installation proceeds as follows:</p> <ul style="list-style-type: none"> - concentric: Determine the length of the flue pipes and install these with the clamps in accordance with the installation instructions supplied in the package. - twin pipe: Fit the gasket and the twin-pipe connection. Make sure that the gasket is not damaged. Ensure that the flue pipe and the air inlet pipe are not exchanged; the flue pipe is the pipe in the centre below the flue terminal. <p>10. Finally, secure the roof wall clamp and check that all steps have been carried out correctly</p>

10. APPENDIX: Air intake terminals

Wall Terminal Air PP 150 or 200 mm

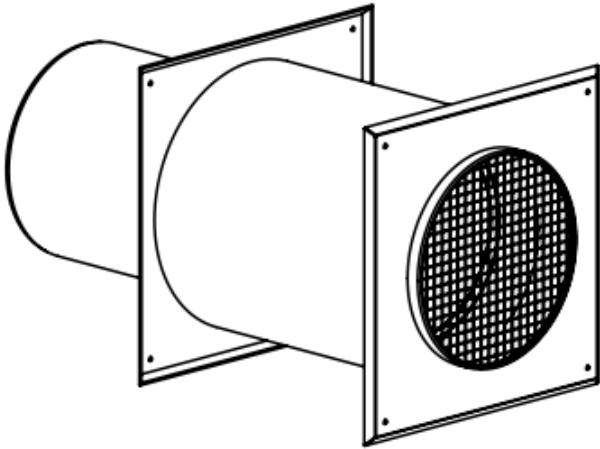

Roof terminal air intake 150, 200 or 250mm



Your distributor:



Eco Heating Systems Groningen B.V.

P.O. Box 5145 9700 GC Groningen
Rigaweg 10 9723 TH Groningen

The Netherlands

T +31 (0)50 5470470
E sales@ecohs.nl
I www.ecohs.nl

