

The next generation condensing units

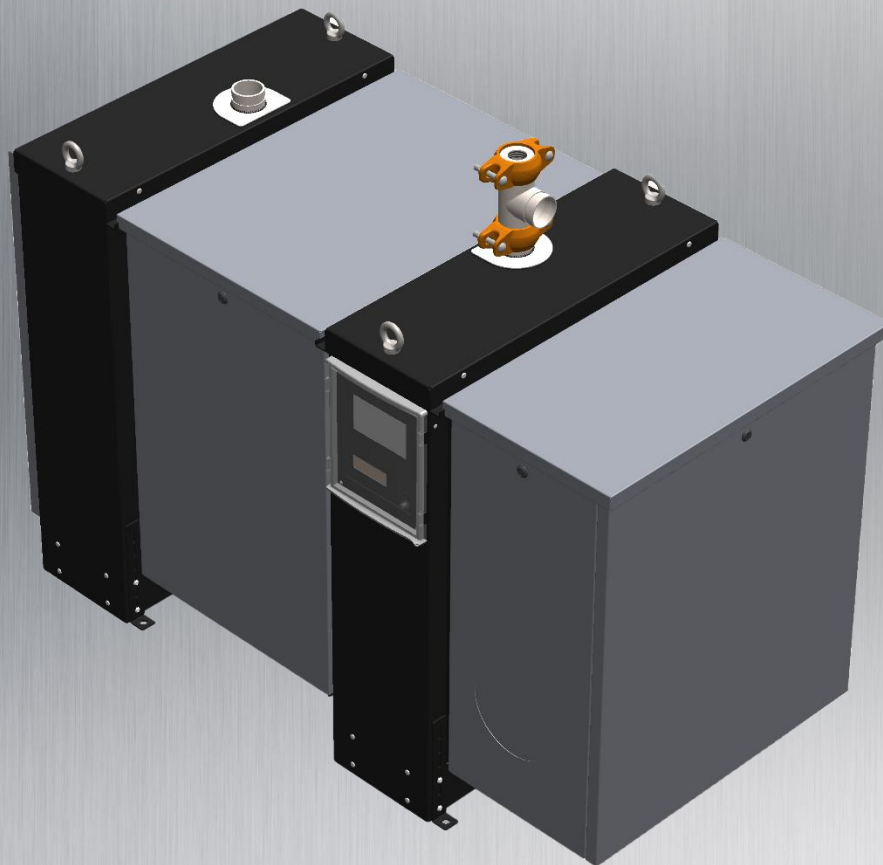

Large commercial and industrial range

Boiler and water heater models available

IB 375 CH / HW
IB 625 CH / HW
IB 875 CH / HW
IB 1200 CH / HW

IB – Large commercial and industrial range

Available in four models: 375, 625, 875 and 1.200 kW

Available in two versions: hot water boiler and potable water heater

Flexible heating specialist

The IB high efficiency, gas condensing units are state-of-the-art condensing boilers and water heaters developed to deliver high performance efficiencies, quality and durability. Using the innovative water tube heat exchanger with increased coil size and double row coils leads to a seasonal efficiency up to 96%! A fully integrated control system with an optional full color touch screen interface provides access to, and continuous monitoring of, critical operating parameters. Additionally, this product will be packaged in an robust enclosure that minimizes required floor space while offering unparalleled access for scheduled services.

Features

- ✓ 316L stainless steel Nnext heat exchanger
- ✓ Seasonal efficiency up to 96%
- ✓ Recovery rate at 60°C of more than 20 m³/h with a single water heater
- ✓ Extreme low NOx emission
- ✓ Full modulation up to 8:1
- ✓ Cascade up to 16 boilers
- ✓ Integrated relays for main power supply and general circulator
- ✓ Easy placement with lifting lugs and side access of a forklift
- ✓ Certified for NG, LPG, Butane and up to 20% Hydrogen
- ✓ Field convertible from natural gas to LPG
- ✓ Levelling castors and wheels optional
- ✓ Outdoor enclosure optional
- ✓ Direct vent flexibility
- ✓ Easy installation and maintenance
- ✓ Available as boiler and water heater

State of the art PCB technology

- ✓ Clear display with graphic design
- ✓ 7 inch touchscreen optional
- ✓ Easy to read fault history
- ✓ Modbus connection standard
- ✓ Bacnet connection optional

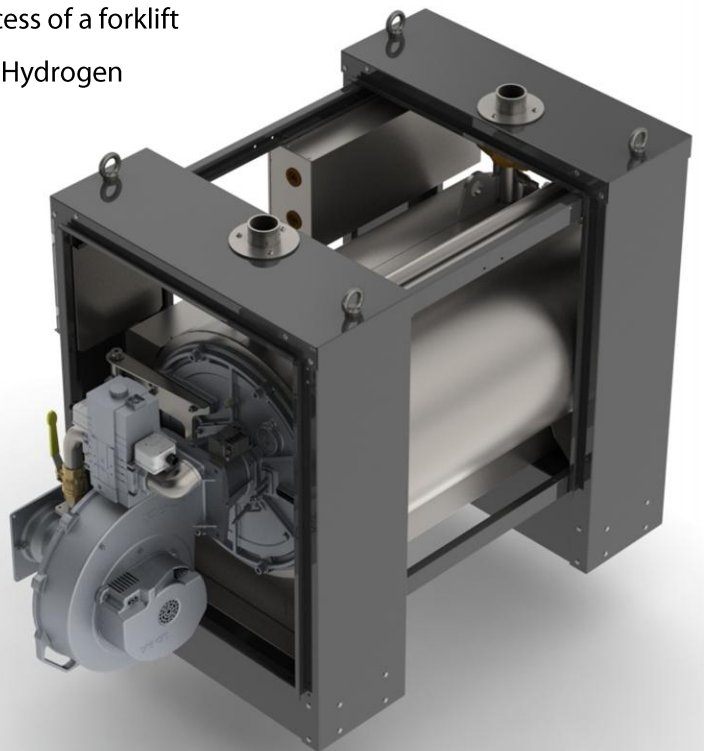

Technical specifications

GENERAL	Unit	IB-375	IB-625	IB-875	IB-1200
Dimensions (l x w x h)	m	1,40x0,87x1,20	1,73x0,87x1,20	2,01x1,17x1,50	2,43x1,17x1,50
Water content	liter	41,5	61,5	130,9	171,4
Weight (empty)	kg	490	600	1015	1330
Flow/return connection	Victaulic	2 ½"	2 ½"	4"	4"
Gas connection	inch	BSP 2"	BSP 2"	BSP 2"	BSP 2"
Flue gas connection	mm	200	200	250	300
Air inlet connection	mm	200	200	300	300
Nominal output 50-30 °C (G20)	kW	54 – 378	91 – 631	126 – 893	145 – 1219
Efficiency (input 30%, return 30°C)	%	>109%			
Seasonal efficiency (Part L)	%	>96%			
Seasonal space heating energy efficiency (η _s)	%	>93%			
Natural gas flow G20 (min – max)	m ³ /h	5,4 – 38,1	9,2 – 63,5	12,7 – 89,9	15,0 – 123,0
Propane flow G31 (min – max)	m ³ /h	2,5 – 14,7	3,8 – 24,5	5,7 – 34,8	5,6 – 47,5
Gas pressure Natural Gas (nominal, min and max)	mbar	20 / 17 / 25			
Gas pressure Propane (nominal, min and max)	mbar	37 / 25 / 45			
Nitrogen Dioxide Emission (NO _x) ¹	mg/kWh	31,7	21,9	26,9	36,9
Flue gas temperature	°C	50 - 80			
Available pressure for the flue system	Pa	250			
Maximum pressure	bar	10,0			
Maximum supply temperature	°C	90 (CH-model) / 85 (HW-model)			
Maximum power consumption	W	450	1.230	1.030	2.100
Appliance amperage	A	4,7	9,7	9,7	3 x 3,0
Power supply	V/Hz	230 / 50 – 60			400 / 50 – 60

¹ Values conform EN15502-1:2021 and used to assign credits according to BREEAM and Ecodesign standards for units up to 1.000 kW

Equipment and terminal connections

Standard boiler equipment

- ✓ Display with easy to use controls to access installer level parameters
- ✓ 7 inch graphical touchscreen optional
- ✓ On/off main power switch
- ✓ Laptop computer connection
- ✓ Supply and return water temperature sensors
- ✓ Integrated water pressure sensor
- ✓ Flue gas temperature sensor
- ✓ Burner door temperature clixon
- ✓ Venturi system for steady gas/air mixture
- ✓ Full 316L stainless steel heat exchanger
- ✓ Premix burner
- ✓ Internal automatic air vent with drain connection
- ✓ Fully serviceable from the front of the boiler
 - All panels at the front side can be removed for easy access to the heat exchanger
 - Heat exchanger contains a sliding arm to open the burner door
- ✓ Opening at the left front side to directly connect the air inlet pipe to the venturi for sealed combustion
- ✓ Integrated low water cutoff
- ✓ Condensate trap
- ✓ Twin pipe flue gas outlet connection on the rear side
- ✓ Flue material of stainless steel and PP allowed to be used
- ✓ Negative draft common flue systems allowed
- ✓ External ignition transformer by default
- ✓ Direct-spark Ignition

High voltage connections

- ✓ Boiler circulator through relay
- ✓ System circulator through optional relay
- ✓ DHW circulator through optional relay
- ✓ DHW TWV (3-way valve)
- ✓ Alarm (dry contact)
- ✓ Flame signal (dry contact)

Low voltage connections

- ✓ Outdoor temperature sensor
- ✓ System temperature sensor
- ✓ DHW temperature sensor
- ✓ Modbus
- ✓ Cascade connection
- ✓ 0-10V VDC input
- ✓ 0-10V circulator control
- ✓ PWM circulator control
- ✓ On/off thermostat or OpenTherm heating circuit
- ✓ External low water cutoff safety
- ✓ Universal safety contact set 1
- ✓ Universal safety contact set 2

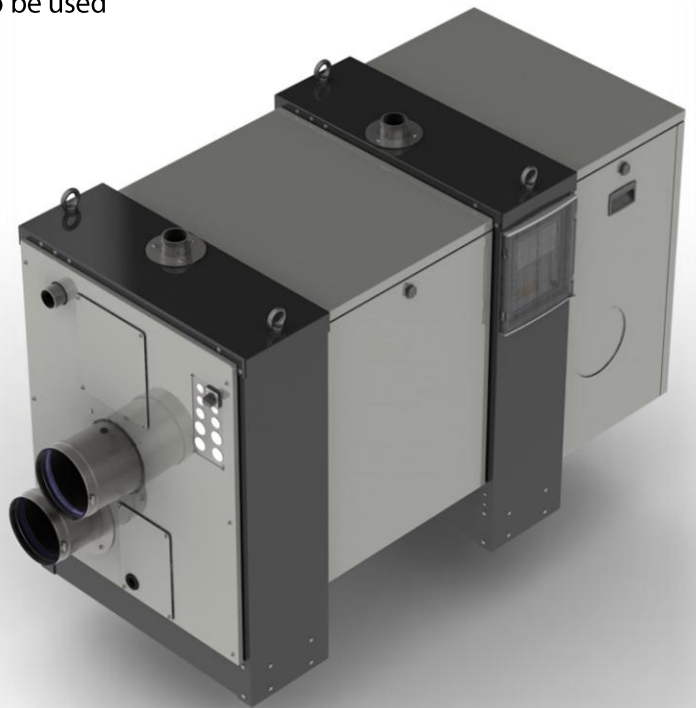

Features and benefits

Boiler control

- ✓ Large backlit LCD screen and optional 7 inch touchscreen with easy to read full text information, programming and errors
- ✓ 16 languages integrated

Additional features

- ✓ Two level frost protection
- ✓ Short cycle protection
- ✓ Adjustable minimum and maximum power
- ✓ Temperature boost function (CH only)
- ✓ Multiple levels of security
- ✓ Field convertible to LPG and butane
- ✓ Maximum flow temperature of 90°C with CH-model and 85°C with HW-model
- ✓ Maximum water pressure of 10 bar
- ✓ Turn down ratio up to 8:1
- ✓ Low gas pressure operation of 17 mbar with NG and 37 mbar with LPG
- ✓ Available pressure for flue system of 200 Pa

Cabinet

- ✓ Removable panels for easy access
- ✓ Compact design with small footprint
- ✓ Easy placement with lifting lugs and side access of a forklift
- ✓ Small footprint because of limited required service clearance: 60 cm left, 5 cm right and 50 cm at the front, rear and top side

Data logging

- ✓ Error logging with time and date stamp
- ✓ Boiler history logging
- ✓ Real time and date clock
- ✓ Days of operation
- ✓ Heating burner runtime hours
- ✓ DHW burner runtime hours
- ✓ Successful and failed ignition attempts
- ✓ Flame failures
- ✓ Last 15 lockout errors
- ✓ Hours since last- and until next service
- ✓ Total days of boiler operation

Outdoor temperature control

- ✓ Easy to setup and program full weather dependent compensation with graphically displayed and adjustable curves
- ✓ Warm weather shutdown
- ✓ Night setback (CH only)



Cascade program options

- ✓ Integrated cascade control
- ✓ Cascade control of up to 16 boilers
- ✓ Remote operation and heat demand indication from each boiler
- ✓ Four cascade power program modes
- ✓ Cascade control for both heating and DHW
- ✓ Boiler sequencing and rotation control

Circulator controls

- ✓ 0-10V and PWM control for variable speed circulators
- ✓ Relays for connection of the boiler-, system- and DHW circulators
- ✓ Circulator exercise function
- ✓ Circulator overrun function
- ✓ Additional alternate functionality for air dampers and 3-way valves

External control and BMS options

- ✓ Modbus connection standard
- ✓ 0-10 VDC remote flow temperature (set point) control (CH only)
- ✓ 0-10 VDC remote boiler power output control (CH only)

Multiple DHW control options

- ✓ DHW Priority
- ✓ CH Priority
- ✓ Parallel DHW and CH operation
- ✓ DHW priority with time out to CH
- ✓ DHW plate heat exchanger control option
- ✓ Anti-legionella program when used with indirect tank sensor

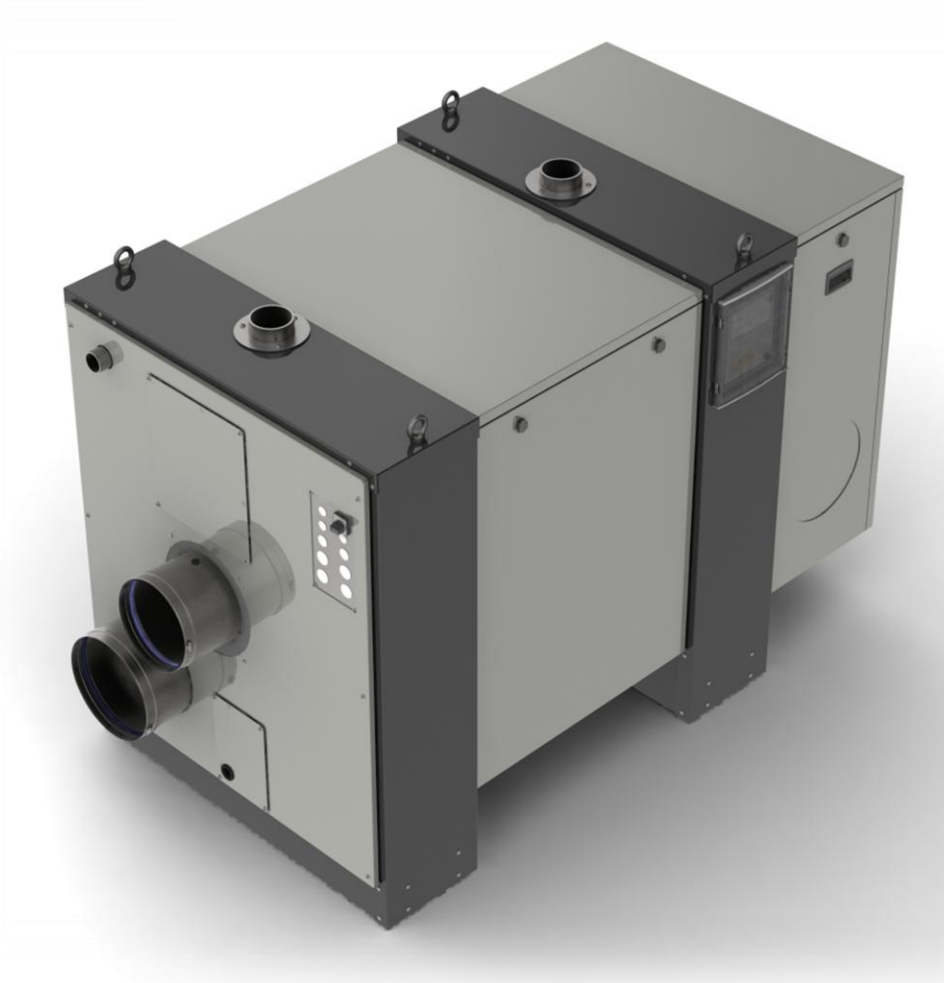
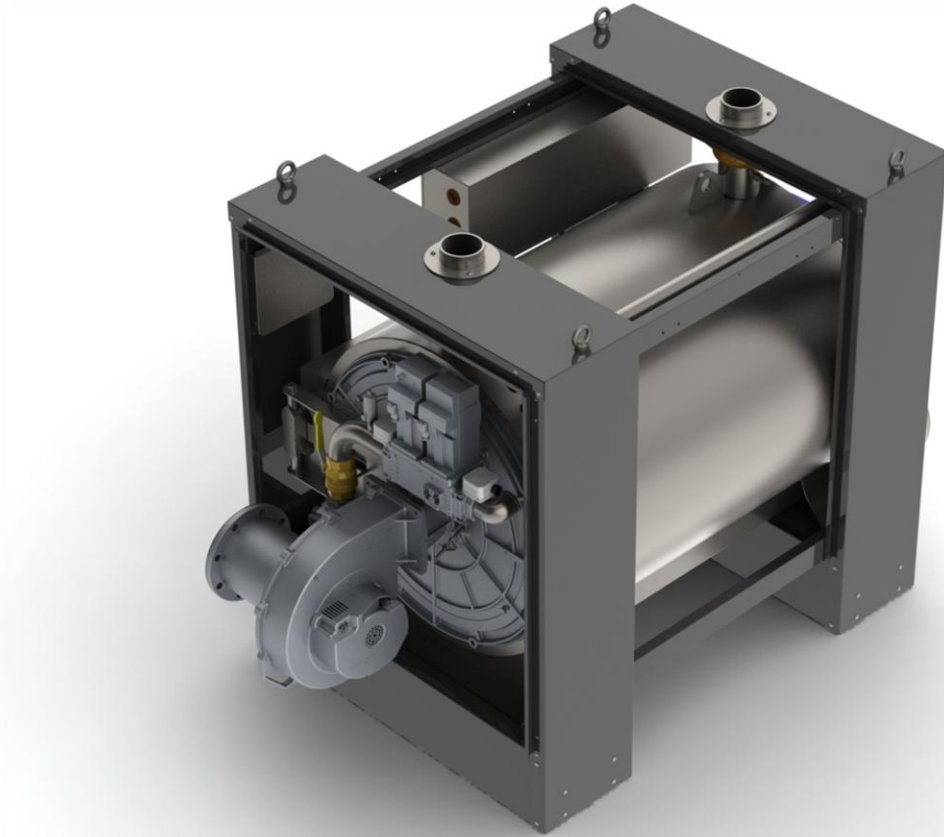



P,O, Box 5145
9700 GC Groningen
The Netherlands



Rigaweg 10
9723 TH Groningen
The Netherlands



T + 31 50 547 04 70
sales@ecohts.nl
www.ecohts.nl